

**unico**

perchè non esiste un altro climatizzatore per veicoli industriali capace di offrirvi il caldo o il freddo quando lo volete voi.

**potente**

perchè capace di offrirvi fino a 7000 Btu/h, raggiungendo le massime condizioni di benessere in pochissimi istanti e garantendovi un funzionamento supersilenziato.

**universale**

perchè lo potrete montare su qualunque cabina di qualunque veicolo industriale, grazie ai suoi specifici kit di finitura.

**unique**

because this is the only truck air conditioner in the world which can both chill or heat up your cabin as per your choice.

**powerful**

because the Roadwind 7000T can offer 7000 BTU/h air-conditioning power, reaching very quickly the best comfort conditions giving you a super-noisless running mode.

**universal**

because you can fit it in every cabin of every truck thanks to its dedicated kits of installation.

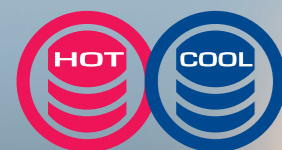

La nuova serie di climatizzatori da tetto ad uso stazionario con pompa di calore



The new serie of roof-air conditioners for a stationary use with heating pump



**RW 3300 T**  
**RW 7000 T**

**CLIMATIZZATORI DA TETTO**  
AD USO **STAZIONARIO**  
CON **POMPA DI CALORE**

**ROOF-AIR CONDITIONERS**  
FOR A **STATIONARY USE**  
WITH **HEATING PUMP**



FUNZIONI E DOTAZIONE / FUNCTIONS AND DOTATION	RW3300T	RW7000T
Regolazione temperatura / Temperature setting	•	•
Regolazione velocità ventilatori su 4 livelli / Blower speed setting on 4 levels	•	•
Programmi di regolazione potenza / Programs of cooling power setting	3	6
Funzione orologio e sveglia / Clock and alarm-clock function	•	•
Timer accensione e spegnimento / Switching on-off timer	•	•
Funzione di autodiagnostica / Auto-diagnostic function	•	•
Funzione salva batteria / Battery saving	•	•
Sensore di spegnimento con cabina inclinata / Tilting sensor	•	•
Illuminazione di cortesia a led a luce diffusa / Internal courtesy led light	•	•
Sistema pompa di calore/ Cooling-Heating mode (patent pending)	•	•
Sistema DCS / DCS feature	•	•
Interruttore generale per servizio di assistenza / Main power switch for service	•	•
N. compressori a 24Vcc / No. of compressors 24Vdc	1	2
Resa frigorifera max / Max cooling capacity	3250 Btu/h	7000 Btu/h
Gas refrigerante / refrigerating gas	R134A	R134A
Numero bocchette orientabili / number of rotary air opening	8	4 (*)
Telecomando / remote control	Standard	Standard

N. 3 per RW7000T per botola piccola / No. 3 for little sun roof RW7000T



**Vitrifrigo** s.n.c. via della Produzione, 9  
61020 Montecchio - Pesaro Urbino - Italy  
tel. +39 0721 491080 fax +39 0721 497739  
marketing@vitrifrigo.com www.vitrifrigo.com



design@vitrifrigo.it



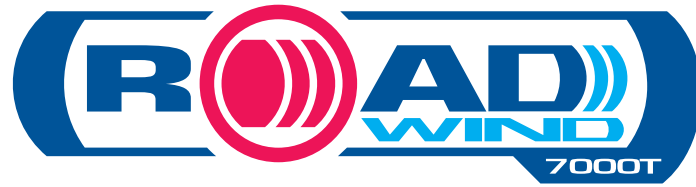

7000 btu

## Installazione Immediata

Con la semplice rimozione della botola - grande o piccola che sia - della cabina, creerete l'alloggiamento per il vostro modello di Roadwind, che fisserete senza necessità di ulteriori forature, assicurandolo dall'interno con la cornice di finitura in dotazione al kit specifico per il vostro veicolo. Roadwind è subito pronto all'uso. Di notte o di giorno. Al caldo o al freddo.

## Immediate Installation

By simply removing the sun roof, either the small or the bigger one, you'll get the housing needed for the installation of your Roadwind with no need of additional screw-holes, fixing it from the inside with the fitting frame provided for your specific vehicle. Roadwind is ready to use.

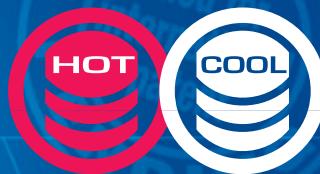

Il primo climatizzatore al mondo con pompa di calore. Finalmente si può avere un caldo tepore senza essere obbligati a lasciare acceso il motore del veicolo, salvaguardando così l'ambiente...e il portafogli!

The first air conditioner for trucks in the market with heating pump. You can finally have a warm ambient inside your cabin, but you won't be obliged to leave your engine on. You'll have the chance to be friendly with the environment and with your pockets.

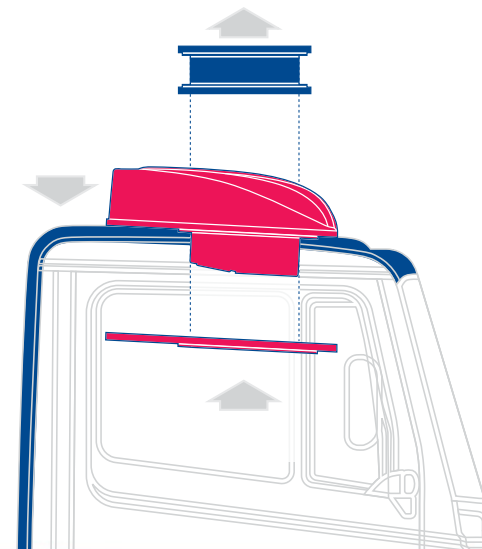

3300 btu

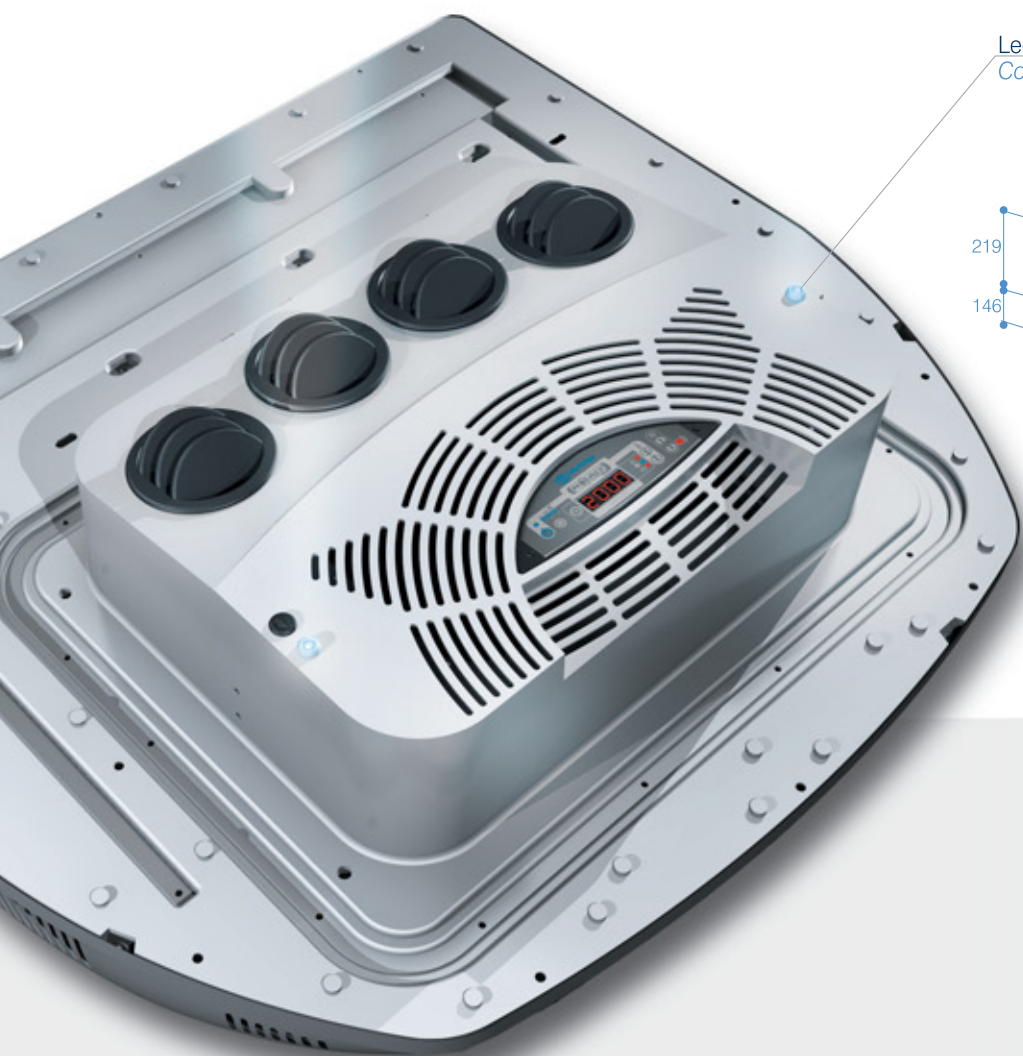

Led di cortesia  
Courtesy LED

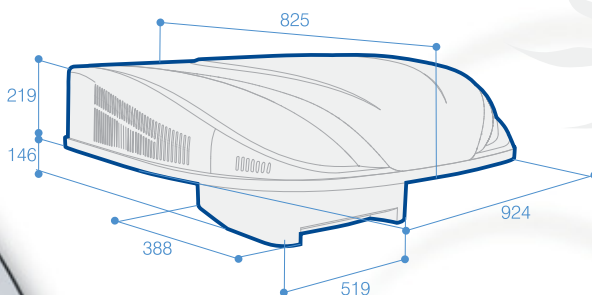

## Occhi rivolti all'ambiente



Il sistema a pompa di calore permette un sensibile risparmio di uso di combustibile, raggiungendo un immediato beneficio in termini ambientali dovuto alle minori emissioni nocive nell'atmosfera.

The heat pump system allows a considerable fuel saving in order to get an immediate benefit in environmental terms, due to the low harmful emissions in the atmosphere.



RW7000T per botola piccola / Little sun roof RW7000T

## Focus on environment



Le pratiche funzioni di Timer per l'accensione e lo spegnimento e di orologio/sveglia vi aiuteranno nell'utilizzo "ecocompatibile" del vostro Roadwind.



The easy on-off switching timer and the time-sleep functions will help you to use your Roadwind in an "ecocompatible" way.

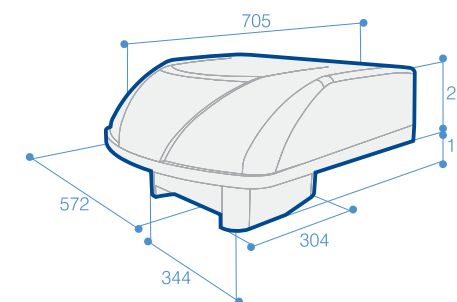

Il Kit esclusivo di montaggio garantisce la tenuta stagna e la perfetta finitura interna del vostro Roadwind.

The exclusive assembly kit guarantees the perfect insulation of your cabin and a perfect internal finish of your Roadwind.

**DAF** mod. LF, XF (excl. Super Space Cab), CF

**IVECO** mod. Stralis e/and Eurocargo (cabina con tetto piano o inclinato / flat and inclined sun roof)

**MAN** mod. TGX, TGA, TGM, TGL

**MERCEDES** mod. Actros

**RENAULT** mod. Premium, Magnum (esclusa la versione 2008 / excl. 2008 version), Kerax

**SCANIA** R, SCANIA 4 (botola elettrica o manuale / electric and manual sun roof)

**VOLVO** mod. FH Globetrotter and FM (botola piccola e cabina XL / small sun roof and XL cabin), FE, FL,

**UNIVERSAL KIT** IVECO mod. Trakker; MERCEDES mod. Axor, Atego



Cornici di finitura interna / Internal finishing frame

