

3-WAYS

VITRIFRIGO
COOL AND BEYOND



1 VTR5070DG 2 VTR5080DG

Total volume	1	2
Capacità totale	61,5 lt.	74 lt.
Freezer compartment		
Vano freezer	8,3 lt.	11 lt.
Net weight		
Peso netto	28 kg.	29,2 kg.
Power supply and nominal consumption	12 Vdc - 110 W 230 Vdc - 130 W	
Alimentazione e consumo nominale	gas - 19,1 g/h	

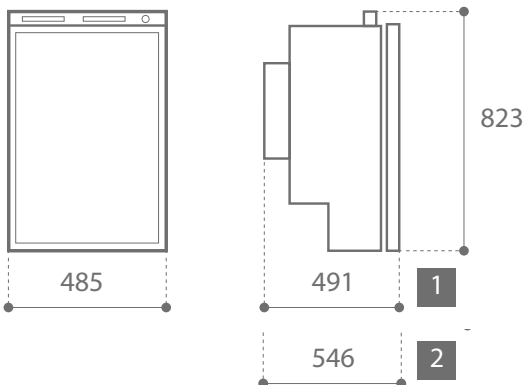

5070

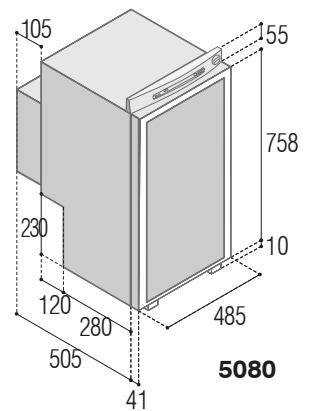
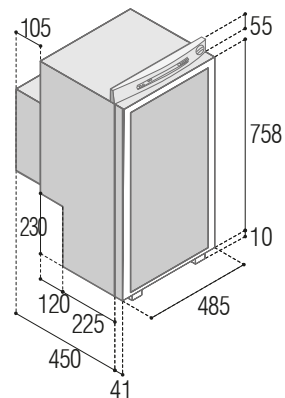



 Everything you need for a perfect installation
TUTTO IL NECESSARIO PER UNA PERFETTA INSTALLAZIONE



1 - COD. R500.555 Top/bottom standard ventilated on grids
Griglia di aerazione superiore-inferiore standard

2 - COD. R500.560 Standard ventilated grid
Griglia di aerazione ventilata standard

3 - COD. R11583 Winter cover kit standard
Kit copertura invernale standard

4 - COD. R12894N.VK Extension set smoke exhaust (*)
Set di prolunghe per scarico fumi (*)

5 - External chimney (*)
Camino esterno (*)

(*) Accessories supplied as standard
Accessori in dotazione al frigo

