

SLIM SERIES

VITRIFRIGO
COOL AND BEYOND



R600a
NextGen compressor



SLIM90 CHR

Total volume Capacità totale	90 lt.
Freezer compartment Vano freezer	10 lt.
Net weight Peso netto	22 kg.
Power supply Alimentazione	12/24 Vdc
Absorption Consumo	270 Wh/24h

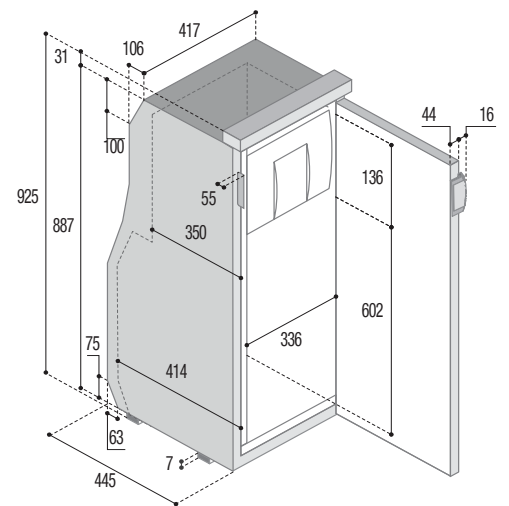
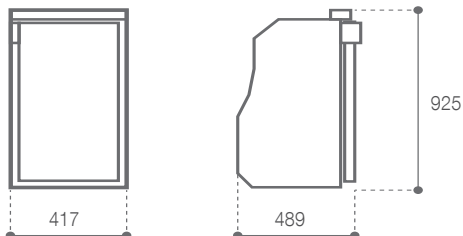

 **Remotable cooling unit**
UNITÀ DI REFRIGERAZIONE REMOTABILE

Up to 1,5
FINO A mt.

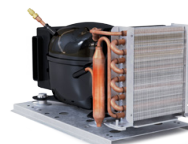



VENT POSITION SYSTEM
SISTEMA VENT POSITION

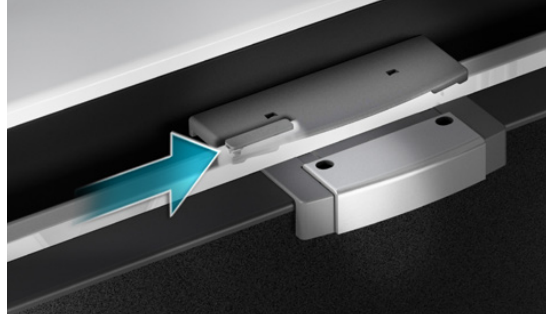

NIGHT MODE

VERY LOW NOISE AND
HIGH ENERGY SAVINGS

SILENZIOSITÀ ASSOLUTA E
RISPARMIO ENERGETICO



TURBO MODE

FAST CHILL SET POINT
TEMPERATURE

RAPIDO
RAGGIUNGIMENTO
DELLA TEMPERATURA



3-STAR FREEZER

FOR FROZEN FOOD
AT -18°C

PER IL CORRETTO
CONGELAMENTO A
-18°C



Finishing panel in two colours: black and light grey
PANNELLO DI FINITURA IN DUE COLORAZIONI: BLACK AND LIGHT GREY



Multi-function thermostat with integrated white led lighting
TERMOSTATO MULTIFUNZIONE CON ILLUMINAZIONE A LED BIANCA INTEGRATA

