



°C +20 -18

VFC15



Total volume Capacità totale	15 lt.
Net weight Peso netto	9,3 kg.
Power supply and nominal consumption Alimentazione e consumo nominale	12/24 Vdc 100-240Vac 50/60Hz 45 W

ARMREST FRIDGE/FREEZER FRIGO/FREEZER DA BRACCIOLO

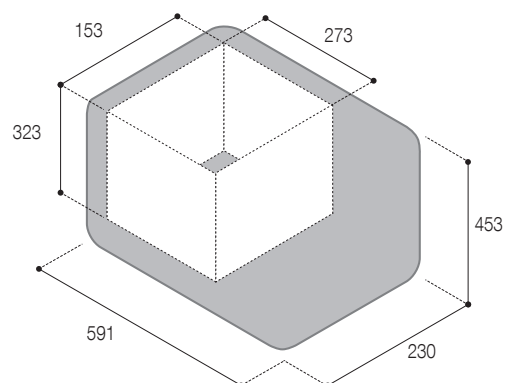
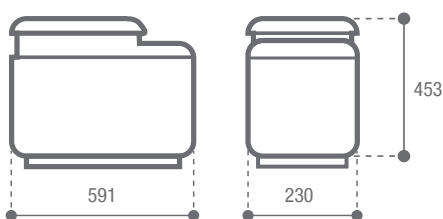

SMART APP CONTROL

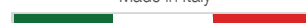

OPTIONAL

COVER
COPERTURA



100/200W Solar Panel
19,5 Vdc - 5,5A



15.600 mAh DETACHABLE LITHIUM ION BATTERY

