

CHROMELOCK SERIES

VITRIFRIGO
COOL AND BEYOND



C85i CHR HP

Total volume Capacità totale	85 lt.
Freezer compartment Vano freezer	12,8 lt.
Net weight Peso netto	20,3 kg.
Power supply Alimentazione	12/24 Vdc
Absorption Consumo	295 Wh/24h



NextGen compressor
COMPRESSORE DI ULTIMA GENERAZIONE

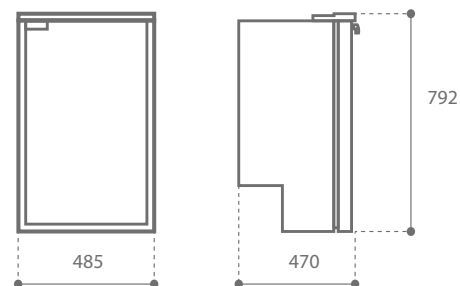

67%
LIGHTER

44%
IMPROVED
EFFICIENCY

40%
SMALLER

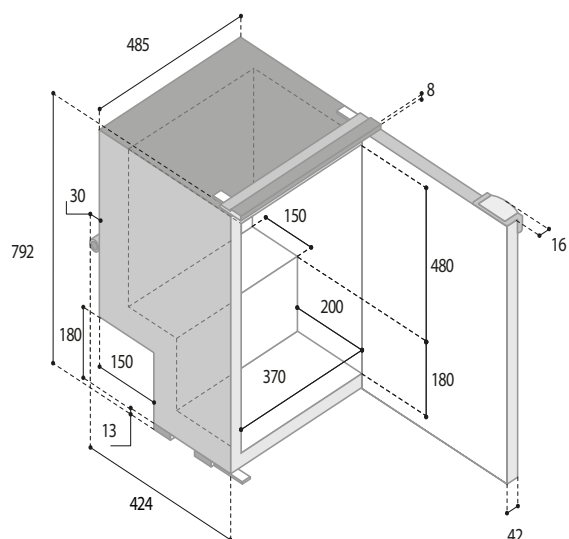

Fridge
Freezer



Optional
POWER
PACK
115-230Vac

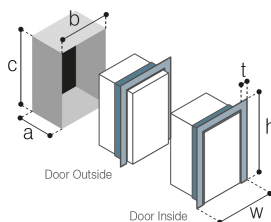

MOUNTING FLANGE
PROFILO DI FISSAGGIO

BUILT-IN
VANO INCASSO

DOOR	INSIDE	OUTSIDE
t:	25	25
w:	548	548
h:	804	804
a:	468	426
b:	503	503
c:	796	796

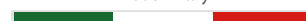

 **Door Inside**
PORTA A FILO INTERNO

 **Door Outside**
PORTA A FILO ESTERNO



INCREASED DOOR THICKNESS
ANTA A SPESSORE MAGGIORATO



ANTI-FINGERPRINT AND SCRATCH RESISTANT FINISH WITH SOFT TOUCH EFFECT
FINITURA ANTI IMPRONTA ED ANTIGRAFFIO CON EFFETTO SOFT TOUCH



REPLACEABLE SEAL
GUARNIZIONE SOSTITUIBILE



METAL FINISH HANDLE
MANIGLIA CON FINITURA METALLIZZATA



VENT POSITION SYSTEM
SISTEMA VENT POSITION



Double door colouring
DOPPIA COLORAZIONE DELLA PORTA



BLACK

LIGHT GREY



Replaceble finishing panel
PANNELLO DI FINITURA SOSTITUIBILE

