

OVERLAND

VITRIFRIGO
COOL AND BEYOND



MADE IN ITALY



Vitrifriigo reserves the right to make any changes deemed appropriate for technical or commercial reasons at any time and without prior notice.

CHROMELOCK SERIES

Fridges and freezers with
internal/external cooling unit

04



SLIM SERIES

Fridges and freezers with
internal/external cooling unit

14



DRW SERIES

All in one stainless steel
drawer fridges and freezers

18



DW SERIES

Stainless steel drawer fridges
and freezers

22



OCX2 SERIES

Stainless steel fridges and freezers
internal/external cooling unit

30



SPECIAL INSTALLATION SERIES

Compact drawer
fridges and freezers

38



TOP LOADING SERIES

Top-loading
fridges and freezers

42



TECHNICAL DRAWINGS

46

CHROMELOCK SERIES



Double door colouring



BLACK | Black matte
soft touch panel

LIGHT GREY | Light grey
glossy panel

Replaceable Finish Panel

Finishing panels
from 1/16 in to 1/8
in. thick.



Integrated Vent Position

Hold the door ajar
during periods of
non-use.

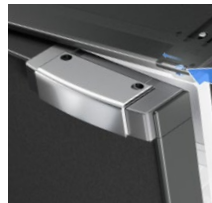

Internal fixing points

Attachment to the recessed
compartment from the inside
(selected models).



FRIGDES AND FREEZERS

With Internal/External Cooling Unit



 FRIDGE + FREEZER



 FRIDGE
(*) Only with 134a gas version



 DRAWER

Flush Flange

Fitting flange (standard), which by simply sliding it, allows both the totally Cut-out version (flush flange) and the partially Cut-out version (surface flange).



Surface Flange



Removable basket

Drawer models are equipped with a removable additional basket to maximize beverage storage.

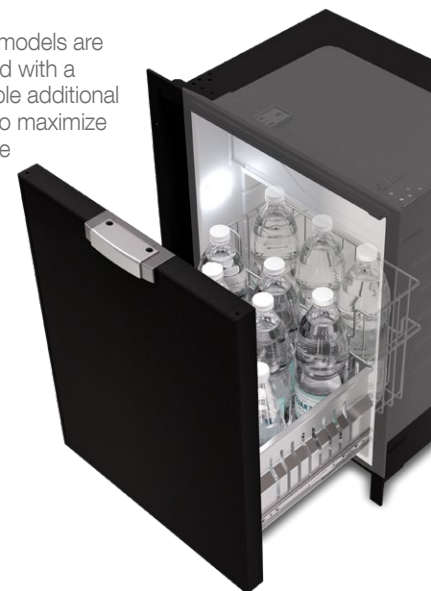

Power supply

115-230Vac 50/60Hz 24Vdc/300W

DP260i CHR C130LD CHR HP C85iD CHR HP
DP150iD CHR C115iD CHR HP DP260i CHR
C95LD CHR HP DP150i CHR



Dual electronic control

12-24Vdc 115-230Vac 50/60Hz

DP2600i C85i CHR C51DWi CHR
DP150i CHR C75L CHR C50i CHR
C130L CHR C75DWL CHR C42L CHR
C115i CHR C62i CHR C42DWL CHR
C95L CHR C62DWi CHR C39i CHR
C90i CHR C60i CHR
C90DWi CHR C51i CHR



Internal LED light

Internal LED lighting with high brightness and minimum consumption.

CHROMELOCK SERIES

TOUCH THE FUTURE
MAXIMIZED PERFORMANCE IN A COMPACT DESIGN



Tailor made for
mobile cooling



Low noise and
vibrations

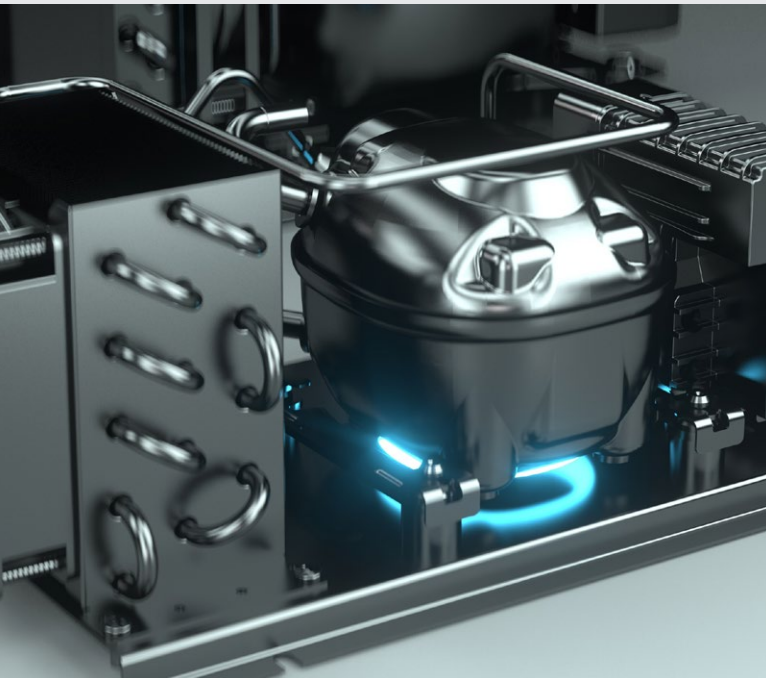

HP NextGen
Compressor



R600a

Vitrifigo features next-generation compressor cooling technology specifically developed for the recreational vehicle sector.

It is not just an alternative but the only solution capable of fully meeting the needs of every traveler, providing reliable support on any journey and in any situation.

No other system can deliver the same performance: thermoelectric and three-way systems consume significantly more energy.

R134a
Compressor



CHR
COOLING UNIT

Weight: 13.2 lbs.

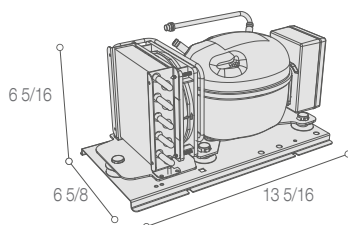

The CHROMELOCK series is available in both CHR and CHR **HP** versions.

Except for:
DP2600i, DP260i CHR, DP150i CHR, C25LP

Dimensions refer to models with external cooling unit

CHR HP
COOLING UNIT

Weight: 6.6 lbs.



R600a
NextGen
Compressor

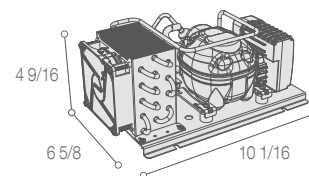

FRIDGES AND FREEZERS

With Internal/External Cooling Unit

44% IMPROVED
HIGH
EFFICIENCY

67% LIGHTER

40% SMALLER



Remotable Cooling Unit

UP TO 4.9 ft. More volume inside the fridge and more installation possibilities for all models with external cooling unit.

Available
models

Total
volume
Cu. Ft.



DIGITAL	Model	Total volume Cu. Ft.	UL US LISTED	Configuration		
				Fridge/Freezer	Fridge	Drawer
	DP260iD CHR	7.6	■	■		
	DP150iD CHR	5.3	■	■		
	C130LD CHR HP	4.6		■		
	C115iD CHR HP	4.1		■		
	C95LD CHR HP	3.4		■		
	C85iD CHR HP	3.0		■		
	DP260i CHR	7.6		■		
	DP2600i (*)	8.1	■	■		
	DP150i	5.3	■	■		
	C130L	4.6	■	■	□	
	C115i	4.1	■	■	□	
	C95L	3.4	■	■	□	
	C90i	3.2	■	■		
	C90DWi	3.2	■	■		■
	C85i	3.0	■	■	□	
	C75L	2.6	■	■	□	
	C75DWL	2.6	■	■	□	■
	C62i	2.2	■	■		
	C62DWi	2.2	■	■		■
	C60i	2.1	■	■	□	
	C51i	1.8	■	■		
	C51DWi	1.8	■	■		■
	C50i	1.8	■	■	□	
	C42L	1.5	■	■	□	
	C42DWL	1.5	■	■	□	■
	C39i	1.4	■	■	□	

(*) Until stocks last

■ From 2027

■ Standard
□ Optional

Fridge/Freezer

Fridge

Drawer



NEW DIGITAL LINE

Smarter Fridges for Smarter Vehicles



Smart app
CONTROL

UPGRADE YOUR ONBOARD COMFORT

The new compressor refrigerators with electronic LED thermostat and app control give you smarter temperature management, more efficiency, and total control from your smartphone.

DP260iD CHR
Internal Cooling Unit

R290
Compressor



USE

Temperature setting
Timed shutdown
Timed night mode
Timed turbo mode

CONTROL

Data display
Error display
Service communication
Push notification



VENTILATED
FRIDGE



HIGH BRIGHTNESS
LED LIGHT



HIGH LOADING
CAPACITY



INTERNAL
FIXING POINTS



DP150D CHR

Internal Cooling Unit

R290
Compressor



C130LD CHR HP

R600a
NextGen
Compressor



External Cooling Unit

C115ID CHR HP

Internal Cooling Unit

R600a
NextGen
Compressor



C95LD CHR HP

R600a
NextGen
Compressor



External Cooling Unit

	DP260D CHR	DP150D CHR	C130LD CHR HP	C115ID CHR HP	C95LD CHR HP	C85D CHR HP
Total volume (Cu.Ft.)	7.6	5.3	4.6	4.1	3.4	3.0
Freezer compartment (Cu.Ft.)	2.0	1.2	0.6	0.6	0.5	0.5
12-24 Vdc (Standard)	•	•	•	•	•	•
115-230Vac 50/60Hz (Optional)	•	•	•	•	•	•
Consumption (Wh/24h)	655	670	274	316	331	338
Net weight (lbs.)	112.4	61.7	59.5	57.3	42.5	44.8
Dimensions (in.)						
H	53 13/16	44 2/16	31 3/16	31 2/16	32 3/16	32 3/16
W	24 13/16	23 3/16	23 2/16	23 2/16	21 9/16	21 9/16
D	22 11/16	20 14/16	22 4/16	22 1/16	18 9/16	18 8/16



C85ID CHR HP

Internal Cooling Unit

R600a
NextGen
Compressor



DP260i CHR

Internal Cooling Unit

R290
Compressor

DP2600i

Internal Cooling Unit

R134a
Compressor

DP150i CHR

Internal Cooling Unit

R290
CompressorAlso
available
as DP150i

C130L CHR | R134a
compressor

External Cooling Unit

C115i CHR | R134a
compressorC95LD CHR | R134a
compressor

External Cooling Unit

C90i CHR | R134a
compressor
Internal Cooling UnitC90DWi CHR | R134a
compressor
Internal Cooling UnitC85i CHR | R134a
compressor
Internal Cooling Unit

	DP260i CHR	DP2600i	DP150i CHR	C130L CHR	C115i CHR	C95L CHR	C90i CHR	C90DWi CHR	C85i CHR
Total volume (Cu.Ft.)	7.6	8.1	5.3	4.6	4.1	3.4	3.2	3.2	3.0
Freezer compartment (Cu.Ft.)	2.0	2.1	1.2	0.6	0.6	0.5	0.3	0.3	0.5
12-24 Vdc (Standard)	•	•	•	•	•	•	•	•	•
115-230Vac 50/60Hz (Optional)	•	•	•	•	•	•	•	•	•
Consumption (W)	N.A.	N.A.	590 (Wh/24h)	45	45	45	42	42	42
Net weight (lbs.)	112.4	116.8	61.7	66.1	63.9	49.2	45.4	52.0	51.4
Dimensions (in.)									
H	53 13/16	53 14/16	44 2/16	31 3/16	31 2/16	32 3/16	25 8/16	25 8/16	32 3/16
W	24 15/16	24 13/16	23 3/16	23 2/16	23 2/16	21 9/16	21	21	21 9/16
D	22 11/16	24	20 14/16	22 4/16	22 1/16	18 9/16	21 9/16	21 9/16	18 8/16



C75L CHR | R134a
compressor

External Cooling Unit

C75DWL CHR | R134a
compressorH max
13 in.

External Cooling Unit

	C75L CHR	C75DWL CHR	C62i CHR	C62DWi CHR	C60i CHR	C51i CHR	C51DWi CHR	C50i CHR	C42L CHR	C42DWL CHR	C39i CHR	
Total volume (Cu.Ft.)	2.6	2.6	2.2	2.2	2.1	1.8	1.8	1.8	1.5	1.5	1.4	
Freezer compartment (Cu.Ft.)	0.4	0.4	0.2	0.2	0.4	0.1	0.1	0.1	0.1	0.1	0.1	
12-24 Vdc (Standard)	•	•	•	•	•	•	•	•	•	•	•	
115-230Vac 50/60Hz (Optional)	•	•	•	•	•	•	•	•	•	•	•	
Consumption (W)	40	40	40	40	40	40	40	40	31	31	31	
Net weight (lbs.)	41.0	47.6	37.0	43.0	41.0	39.7	46.3	39.7	33.1	39.7	35.3	
Dimensions (in.)	H	25 8/16	25 8/16	21 14/16	21 14/16	25 8/16	21 15/16	21 15/16	26	21 15/16	21 15/16	22 8/16
	W	21	21	20 3/16	20 3/16	21	17 7/16	17 7/16	18 1/16	17 7/16	17 7/16	17 13/16
	D	18 2/16	18 2/16	21 5/16	21 5/16	18	20 4/16	20 4/16	15 10/16	15 2/16	15 2/16	15 10/16



C62i CHR | R134a
compressor
Internal Cooling Unit



C62DWi CHR | R134a
compressor
Internal Cooling Unit



C60i CHR | R134a
compressor
Internal Cooling Unit



C51i CHR | R134a
compressor
Internal Cooling Unit



C51DWi CHR | R134a
compressor
Internal Cooling Unit



C50i CHR | R134a
compressor
Internal Cooling Unit



C42L CHR | R134a
compressor



C42DWL CHR | R134a
compressor



C39i CHR | R134a
compressor
Internal Cooling Unit



External Cooling Unit



External Cooling Unit

SLIM SERIES

BUILT AND DESIGNED FOR CAMPERVANS

CLIMATE CLASS: T



Double door colouring



BLACK | Black matte soft touch panel

LIGHT GREY | Light grey glossy panel



NIGHT MODE
Very low noise and high energy savings



TURBO MODE
Fast chill set point temperature



Power supply

Optional
115-230Vac
50/60Hz
24Vdc/300W



Replaceable Finish Panel

Allows panel thickness from 1/16 in to 1/8 in.



Integrated Vent Position

Hold the door ajar during periods of non-use.

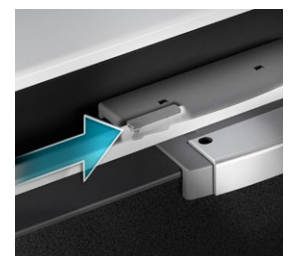

SLIM250 CHR **HP**

2 independent cooling compartments

You decide.
Use both or just one

UP TO 30%
ENERGY CONSUMPTION
SAVING

All in one drawer
CHOOSE AS YOU NEED

More freezer space to fit meat or ice cream or extra refrigerator room for fresh food.



Electronic LED thermostat



Crisper bins

2 x
2.6 Gal.

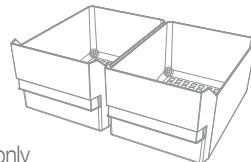

SLIM250 only

SLIM SERIES

BUILT AND DESIGNED FOR CAMPERVANS

Available models	UL LISTED	Total volume
Internal Cooling Unit		Cu. Ft.
SLIM 250 CHR HP	■	8.8
External Cooling Unit		
SLIM 150 CHR	■	5.3
SLIM 90 M CHR	■	3.2
SLIM 90 CHR HP	■ NEW	3.2
SLIM 90i CHR HP	■ NEW	3.2

■ From 2027

HP NextGen
Compressor  R600a

 Tailor made for mobile cooling

 Low noise and vibrations

44% IMPROVED
HIGH
EFFICIENCY

67% LIGHTER

40% SMALLER



Except for SLIM150 and SLIM90M

Removable Cooling Unit

UP TO 4.9 ft. More volume inside the fridge and more installation options.

SLIM250 CHR **HP**

H max
13 12/16 in.

2x R600a
NextGen compressor



INTERNAL COOLING UNIT



NO FROST
Ventilated Cooling
System (fridge)



CI BUS READY

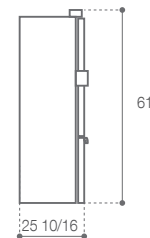
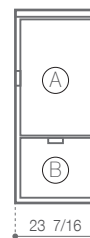

(A) Ventilated
fridge
6.7 Cu. Ft.

(B) Drawer
fridge/freezer
2.1 Cu. Ft.

SLIM150 CHR



H max
14 6/16 in.

1x R290
Compressor



EXTERNAL COOLING UNIT

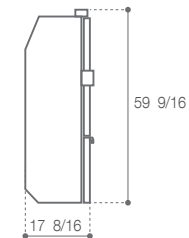
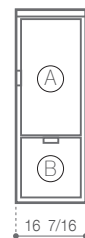

(A) Fridge with 0.6 Cu. Ft. 3-Star
freezer compartment
3.2 Cu. Ft.

(B) Drawer
fridge
2.1 Cu. Ft.

SLIM90M CHR

MECHANICAL THERMOSTAT



1x **R134a**
compressor

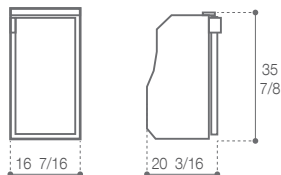

EXTERNAL COOLING UNIT

SLIM90 CHR **HP**

1x **R600a**
NextGen compressor

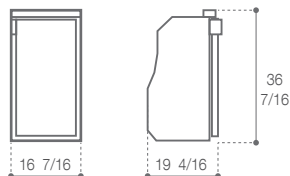

EXTERNAL COOLING UNIT

SLIM90i CHR **HP**

1x **R600a**
NextGen compressor



BOTTOM COOLING UNIT

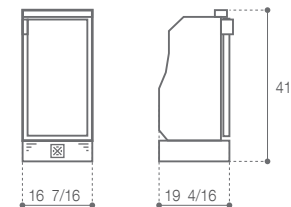

Fridge with 0.4 Cu. Ft. 3-Star
freezer compartment

SLIM 90M CHR - SLIM 90 CHR HP - SLIM 90i CHR HP

		SLIM250 CHR HP	SLIM150 CHR	SLIM90M CHR	SLIM90 CHR HP	SLIM90i CHR
Total volume	(Cu. Ft.)	8.8	5.3	3.2	3.2	3.2
Freezer compartment	(Cu. Ft.)	2.1 (drawer)	0.6	0.4	0.4	0.4
Net weight	(lbs.)	134.5	81.6	55.1	48.5	41.9
Power supply	(Vdc)	12/24	12/24	12/24	12/24	12/24
Consumption	(Wh/24h)	350(A) - 110(B)**	680*	270*	270*	260*
Climate class		T	ST	T	T	T

(**) Compartment B as fridge mode - T int. 41 °F - T ext. 77 °F

(*) T int. 41 °F - T ext. 77 °F

DRW SERIES

R290
Compressor



Flush flange or Surface Flange



Flush or external door through the translation of the fitting flange, equipped with slots for better air circulation and more efficient cooling.

ALL IN ONE STAINLESS STEEL DRAWERS

FRIDGES AND FREEZERS

THE ONLY ONE THE ALL IN ONE

YOU DECIDE.
ANY TEMPERATURE,
ANY TIME.

Available models	Total volume
	Cu. Ft.
DRW360A	5.5 + 5.3
DRW180A	5.3
DRW70A	2.8

New generation drawers

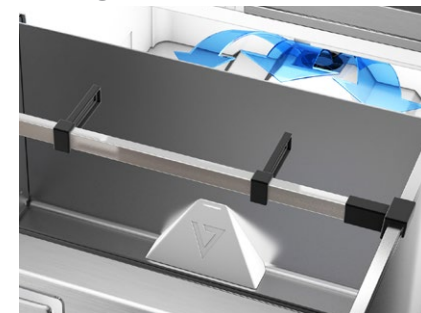

Thermostat with touch screen

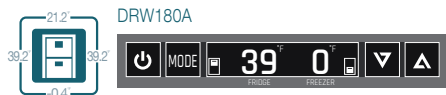

FRIDGE OR FREEZER (39.2°F) (-0.4°F)

	Upper Drawer Cassette sup.	Lower Drawer Cassette inf.
FRIDGE ONLY	(39.2°F)	(39.2°F)
FRIDGE + FREEZER	(21.2°F)	(-0.4°F)
FREEZER ONLY	(21.2°F)	(-0.4°F)

3-Star freezer + total no frost

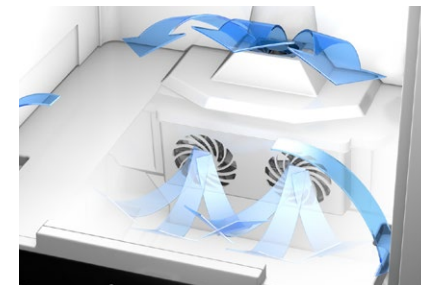

Optional Power Supply



115-230Vac
50/60Hz
24Vdc/300W



Integrated Vent Position



Hold the door ajar during periods of non-use.

Remotable Cooling Unit

UP TO 4.9 ft.
More volume inside the fridge and more installation options.



Internal fixing points

Attachment to the recessed compartment from the inside (except for DRW360).



DRW360A

Internal Cooling Unit

H max
11 in.H max
11 7/16 in.

Daily consumption

(T_{ext.} = 77°F)

A	B	°F	Wh/24h
Set 46.4°F 500 Wh/24h	Fridge/Fridge	39.2 / 39.2	600
Set 39.2°F 600 Wh/24h	Fridge/Freezer	39.2 / -0.4	1100
Set 35.6°F 700 Wh/24h	Freezer/Freezer	21.2 / -0.4	1200

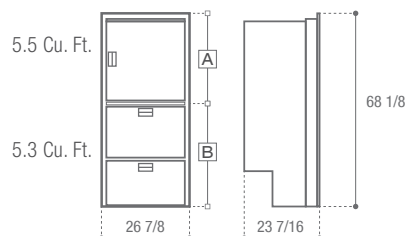

Perfect combination of DRW180A (all-in-one fridge-freezer) and C180iX (only fridge), the latter configured with the new digital thermostat.

DRW180A



Internal Cooling Unit

H max
11 in.H max
11 7/16 in.Daily consumption (T_{ext.} = 77°F)

	°F	Wh/24h
Fridge/Fridge Frigorifero/Frigorifero	39.2 / 39.2	600
Fridge/Freezer Frigorifero/Congelatore	39.2 / -0.4	1100
Freezer/Freezer Congelatore/Congelatore	-0.4 / -0.4	1200

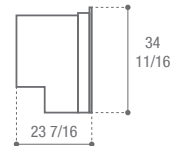

DRW70A

INTERNAL
FIXING POINTSH max
11 in.Daily consumption (T_{ext.} = 77°F)

	°F	Wh/24h
Fridge Frigorifero	39.2	250
Freezer Congelatore	-0.4	1100

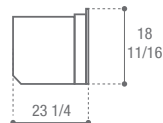

External Cooling Unit

		DRW360A	DRW180A	DRW70A
Total volume (Cu. Ft.)		5.5 + 5.3	5.3	2.8
Net weight (lbs.)		220.5	121.3	83.8
Power supply		12-24 Vdc	12-24 Vdc	12-24 Vdc
Max absorbed power during Defrost	(12-24 Vdc)	(A) - (B) 130 W	130 W	130 W
Max consumption power during Defrost	(12-24 Vdc)	(A) - (B) 10,5A	10,5A	10,5A
Max consumption - Normal Operation	(12Vdc)	(A) 4A (B) 8A	8A	8A
Max consumption - Normal Operation	(24Vdc)	(A) 2A (B) 4A	4A	4A

Power Pack (OPTIONAL)
115-230Vac 50/60Hz

•

•

•

DW SERIES



Flush flange or Surface Flange

Flush or external door through the translation of the fitting flange, equipped with slots for better air circulation and more efficient cooling.



STAINLESS STEEL DRAWERS

FRIDGES AND FREEZERS



Available models	Total volume
	Cu. Ft.
DW360 OCX2	5.5+2.8+2.3
DW250 OCX2	5.5+2.6
DW210 OCX2	2.8+3.7
DW180 OCX2	2.8+2.3
DW100 OCX2	3.4
DW70 OCX2	2.6
DW35 OCX2	1.2
<hr/>	
DW90i OCX2 DRINKS	3.2
DW62i OCX2 DRINKS	2.2
DW51i OCX2 DRINKS	1.8

New generation drawers

The new drawer sliding guides ensure a perfect closure and a smooth, silent movement. Additionally, the drawers are equipped with internal dividers to optimize the distribution of contents.

Precise temperature control

Temperature control is managed by an innovative electronic LED thermostat providing maximum precision in selecting refrigeration degrees.

Internal LED light system



All models (with the exception of the DW35) are equipped with an internal LED light system that offers high brightness with minimum consumption.

Internal icemaker



DW360 OCX2, DW210 OCX2, DW180 OCX2 and DW70 OCX2 only

OPTIONAL



Dual electronic control

12-24Vdc
115-230Vac
50/60Hz



Integrated Vent Position



Hold the door ajar during periods of non-use.

Remotable Cooling Unit

UP TO 4.9 ft.
More volume inside the fridge and more installation options.



Internal fixing points

Attachment to the recessed compartment from the inside (except for DRW360).



DW360 OCX2

Internal Cooling Unit

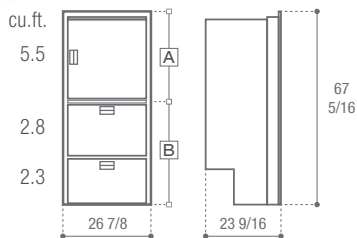

1	1	1	1
2	2	3	3
2	1	2	1
BTX	DTX	BTX IM	DTX IM

DW250 OCX2

Internal Cooling Unit

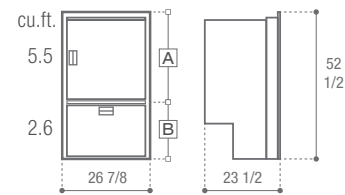

1	1
1	2
RFX	BTX

		DW360 OCX2	DW250 OCX2	DW210 OCX2	DW180 OCX2	DW100 OCX2	DW70 OCX2	DW35 OCX2
Net weight (lbs.)	BTX-DTX / BTX IM-DTX IM	224.9/235.9	147.7	134.5/147.7	123.5/134.5	70.5	72.8/83.8	55.1
Power supply and Consumption (Wh/24h)	RFX (12-24 Vdc)	-	(A)450/(B)250 Wh/24h	440 Wh/24h	400 Wh/24h	400 Wh/24h	250 Wh/24h	300 Wh/24h
	BTX (12-24 Vdc)	(A)450/(B)400 Wh/24h	(A)450/(B)570 Wh/24h	860 Wh/24h	815 Wh/24h	910 Wh/24h	570 Wh/24h	690 Wh/24h
	DTX (12-24 Vdc)	(A)450/(B)815 Wh/24h	-	740 Wh/24h	700 Wh/24h	-	-	-
	BTX IM (115Vac)	(A) N.A./ (B)700 Wh/24h	-	860 Wh/24h	N.A.	-	N.A.	-
	BTX IM (230Vac)	(A) N.A. / (B) N.A.	-	N.A.	N.A.	-	N.A.	-
	DTX IM (115Vac)	(A) N.A. / (B) N.A.	-	N.A.	N.A.	-	-	-
	DTX IM (230Vac)	(A) N.A. / (B) N.A.	-	N.A.	N.A.	-	-	-
D-Power (OPTIONAL) 12-24Vdc 115-230Vac 50/60Hz		•	•	•	•	•	•	•

DW210 OCX2

Internal Cooling Unit



DW180 OCX2

Internal Cooling Unit



DW100 OCX2



External Cooling Unit

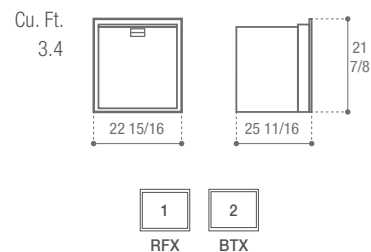
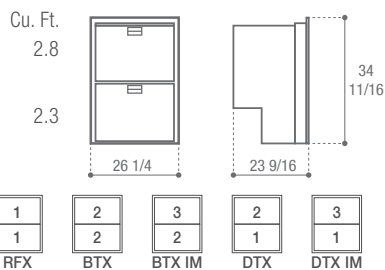
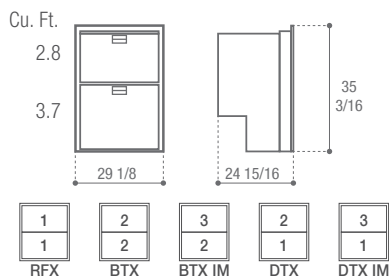

DW70 OCX2



External Cooling Unit

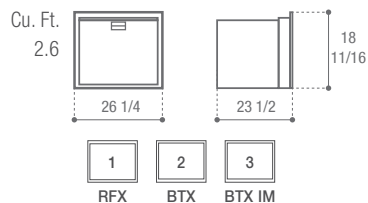

DW35 OCX2



0.1 Cu. Ft. food storage container



External Cooling Unit

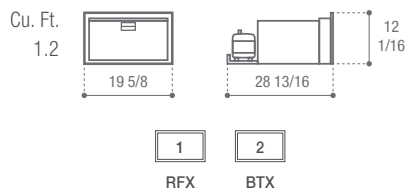



Flush flange or Surface Flange



Integrated Vent Position

The device integrated in the Steelock handle achieves the "vent position" function, allowing the door to be held ajar, thus avoiding the formation of mould and odours during periods of non-use.



Flush or external door through the translation of the fitting flange, equipped with slots for better air circulation and more efficient cooling.

STAINLESS STEEL

DRAWER FRIDGES AND FREEZERS

CHEERS!

Designed to offer even greater comfort onboard, the “Drinks Series” is mainly dedicated to drinks and beverages storage.

The drinks placement is made easy thanks to a sliding basket on the upper part of the drawer, equipped with a drawer separator for three 0.5 gallons bottles.

Available models	Total volume
	Cu. Ft.
DW90i OCX2 DRINKS	3.2
DW62i OCX2 DRINKS	2.2
DW51i OCX2 DRINKS	1.8

Precise temperature control

The new electronic LED thermostat has 5 default settings to guarantee maximum functionality, relevant to the desired temperature, allowing to get a constant cycle even at 109.4°F!

DW90 OCX2 DRINKS  °F **48.2 / 28.4**

DW62 OCX2 DRINKS  °F **46.4 / 24.8**

DW51 OCX2 DRINKS  °F **46.4 / 21.2**

Ventilated Evaporator

The “Drinks Series” is equipped with a ventilated evaporator allowing constant air recirculation and achieving temperature uniformity inside your refrigerator.



Internal LED light

Internal LED lighting with high brightness and minimum consumption.



REFUEL AND GO!

The Drinks series allows you to fill up on the drinks that best suit your habits.

The interior has been designed to manage differently the space of the drawer and the removable upper basket.

This one, if necessary, is completely and easily removable.

CONFIGURATION WITH UPPER INSERTED BASKET

Drawer front

- DW90: 3 bottles H max 13 3/8 in.
- DW62: 3 bottles H max 12 3/16 in.
- DW51: 3 bottles H max 10 5/8 in.

Drawer back

- DW90: bottles and cans H max 11 in.
- DW62: bottles and cans H max 9 13/16 in.
- DW51: bottles and cans H max 9 7/16 in.

Upper basket

- DW90: bottles and cans H max 6 5/16 in.
- DW62: bottles and cans H max 5 7/8 in.
- DW51: bottles and cans H max 5 7/8 in.

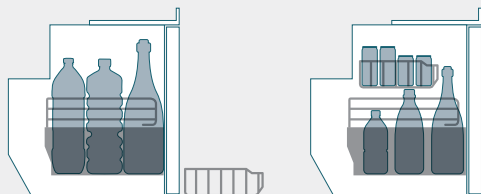

By removing the upper basket, the entire capacity of the refrigerator is available, so that you can freely

store any type of bottle or container you want.

DW90i OXC2 DRINKS

Internal Cooling Unit

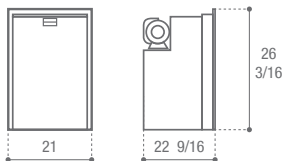

Fridge

DW62i OXC2 DRINKS

Internal Cooling Unit

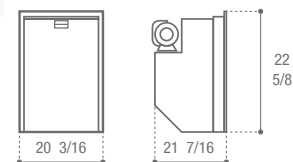

Fridge

DW51i OXC2 DRINKS

Internal Cooling Unit

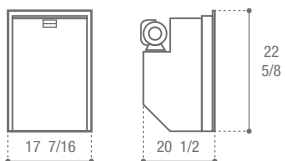

Fridge

	DW90i OXC2 DRINKS	DW62i OXC2 DRINKS	DW51i OXC2 DRINKS
Total volume (Cu. Ft.)	3.2	2.2	1.8
Net weight (lbs.)	66.1	59.5	50.7
Power supply	12-24 Vdc	12-24 Vdc	12-24 Vdc
Consumption	470 Wh/24h	N.A.	300 Wh/24h

OCX2 SERIES

New OCX2 System

The new OCX2 version offers the positive snap closure of the door to avoid accidental openings with integrated Vent Position, to hold the door ajar during periods of non-use. Quick and easy reversibility of the door.



Removable basket

Drawer models are equipped with an additional removable basket to maximize beverage storage.



Optional
Power Pack

Power supply

115-230Vac 50/60Hz
24Vdc/300W



DP260iXD OCX2 - C130LXD OCX2 HP
C115iXD OCX2 HP - C85iXD OCX2 HP - DP260iX OCX2



OPTIONAL
D-E
D-POWER

Dual electronic control

12-24Vdc 115-230Vac 50/60Hz



DP2600iX OCX2 - C180iX OCX2 - C130LX OCX2 - C115iX OCX2
C90iX OCX2 - DW90i OCX2 - C85iX OCX2 C75LX OCX2
DW75L OCX2 - C62iX OCX2 - DW62i OCX2 C60iX OCX2
C51iX OCX2 - DW51i OCX2 - C42LX OCX2 - DW42L OCX2

STAINLESS STEEL FRIDGES AND FREEZERS



FRIDGE + FREEZER



FRIDGE

(*) Only with 134a gas version



DRAWER



Flush flange or Surface Flange

Flush or external door through the translation of the fitting flange, equipped with slots for better air circulation and more efficient cooling.

Integrated Vent Position

A smart device, incorporated in the Steelock handle, realizes the "vent position" function, holding the door ajar during periods of non-use.



Internal LED light

Internal LED lighting with high brightness and minimum consumption.

Remotable Cooling Unit

UP TO 4.9 ft.

More volume inside the fridge and more installation options.



Internal fixing points

Attachment to the recessed compartment from the inside (selected models).



	Cu. Ft.	UL LISTED	Standard	Fridge Freezer	Fridge	Drawer
DIGITAL	DP260iXD OCX2	7.6	■	■		
	C130LXD OCX2 HP	4.6		■		
	C115iXD OCX2 HP	4.1		■		
	C85iXD OCX2 HP	3.0		■		
DP260iX OCX2	7.6			■		
DP2600iX (*)	8.1	■	■			
C180iX OCX2	5.5				■	
C130LX	4.6	■	■	□		
C115iX	4.1	■	■	□		
C90iX	3.2	■	■			
DW90iX	3.2	■	■		■	
C85iX	3.0	■	■	□		
C75LX	2.6	■	■	□		
DW75LX	2.6	■	■	□	■	
C62iX	2.2	■	■			
DW62iX	2.2	■	■		■	
C60iX	2.1	■	■	□		
C51iX	1.8	■	■			
DW51iX	1.8	■	■		■	
C42LX	1.5	■	■	□		
DW42LX	1.5	■	■	□	■	

(*) Until stocks last

■ From 2027

■ Standard
□ Optional

■ Fridge
□ Freezer

■ Fridge

■ Drawer



NEW DIGITAL LINE

Smarter Fridges for Smarter Vehicles



Smart app
CONTROL

UPGRADE YOUR ONBOARD COMFORT

The new compressor refrigerators with electronic LED thermostat and app control give you smarter temperature management, more efficiency, and total control from your smartphone.

DP260iD OCX2
Internal Cooling Unit

R290
Compressor



USE

- Temperature setting
- Timed shutdown
- Timed night mode
- Timed turbo mode

CONTROL

- Data display
- Error display
- Service communication
- Push notification



VENTILATED
FRIDGE



HIGH BRIGHTNESS
LED LIGHT



HIGH LOADING
CAPACITY



INTERNAL
FIXING POINTS



C130LXD OCX2 HP

R600a
NextGen
CompressorC115iXD OCX2 HP
Internal Cooling UnitR600a
NextGen
CompressorC85iXD OCX2 HP
Internal Cooling UnitR600a
NextGen
Compressor

External Cooling Unit

TOUCH THE FUTURE

MAXIMIZED PERFORMANCE IN A COMPACT DESIGN

Tailor made for
mobile coolingLow noise and
vibrations

HP

NextGen
Compressor

R600a

	DP260 iXD OCX2	C130 LXD OCX2 HP	C115 iXD OCX2 HP	C85 iXD OCX2 HP
Total volume (Cu.Ft.)	7.6	4.6	4.1	3.0
Freezer compartment (Cu.Ft.)	2.0	0.6	0.6	0.5
Net weight (lbs.)	136.7	66.1	63.9	57.3
12-24 Vdc (Standard)	•	•	•	•
115-230Vac 50/60Hz (Optional)	•	•	•	•
Consumption (Wh/24h)	N.A.	380	420	430
Dimensions (in.)				
H	53 14/16	31 4/16	31 4/16	32 3/16
W	24 13/16	23 2/16	23 2/16	21 9/16
D	22 11/16	21 15/16	21 15/16	18 6/16

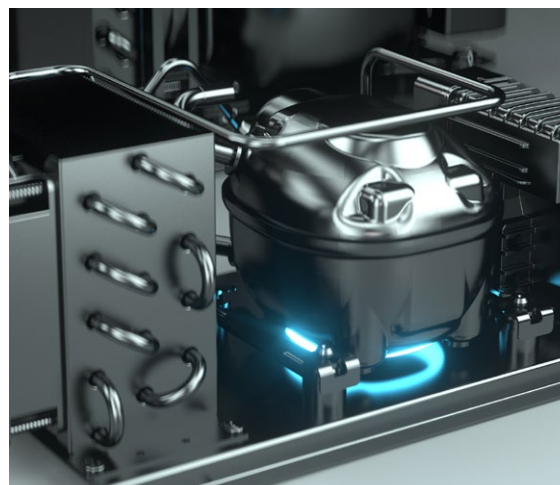

For further informations, see at page 6

DP260iX OCX2 | R290
compressor
Internal Cooling Unit



C180iX OCX2 | R134a
compressor
Internal Cooling Unit



DP2600iX OCX2 | R134a
compressor
Internal Cooling Unit



C130LX OCX2 | R134a
compressor
Internal Cooling Unit



External Cooling Unit

(*) Until stocks last
Fino ad esaurimento merci

C115iX OCX2

R134a
compressor

Internal Cooling Unit

INTERNAL
FIXING POINTS

C90iX OCX2

R134a
compressor

Internal Cooling Unit

INTERNAL
FIXING POINTS

DW90i OCX2

R134a
compressor

Internal Cooling Unit

INTERNAL
FIXING POINTSH max
9 in.

C85iX OCX2

R134a
compressor

Internal Cooling Unit

INTERNAL
FIXING POINTS

	DP 260X OCX2	DP 2600X OCX2	C180X OCX2	C130 LX OCX2	C115 iX OCX2	C90 iX OCX2	DW90i OCX2	C85 iX OCX2
Total volume (Cu.Ft.)	7.6	8.1	5.5	4.6	4.1	3.2	3.2	3.0
Freezer compartment (Cu.Ft.)	2.0	2.1	-	0.6	0.6	0.3	0.3	0.5
Net weight (lbs.)	136.7	125.7	90.4	72.8	70.5	59.5	66.1	63.9
12-24 Vdc (Standard)	•	•	•	•	•	•	•	•
115-230Vac 50/60Hz (Optional)	•	•	•	•	•	•	•	•
Consumption	N.A.	65W	45W	45W	45W	45W	45W	45W
Dimensions (in.)								
H	53 14/16	53 14/16	34 10/16	31 4/16	31 4/16	25 8/16	25 8/16	32 3/16
W	24 13/16	24 13/16	26 9/16	23 2/16	23 2/16	21	21	21 9/16
D	22 9/16	24	22 5/16	21 15/16	21 15/16	21 15/16	21 15/16	18 6/16



C75LX OCX2 | R134a
compressor

External Cooling Unit

DW75L OCX2 | R134a
compressor

External Cooling Unit

H max
12.6 in.C62iX OCX2 | R134a
compressor

Internal Cooling Unit

DW62i OCX2 | R134a
compressor

Internal Cooling Unit

H max
11 in.C60iX OCX2 | R134a
compressor

Internal Cooling Unit

C51iX OCX2 | R134a
compressor

Internal Cooling Unit



DW51i OCX2 | R134a

compressor



Internal Cooling Unit

INTERNAL
FIXING POINTSH max
9.8 in.

C42LX OCX2 | R134a

compressor

INTERNAL
FIXING POINTS

External Cooling Unit

DW42L OCX2 | R134a

compressor

INTERNAL
FIXING POINTSH max
16.5 in.

External Cooling Unit

	C75 LX OCX2	DW75L OCX2	C62 iX OCX2	DW62i OCX2	C60 iX OCX2	C51 iX OCX2	DW51i OCX2	C42 LX OCX2	DW42L OCX2
Total volume (Cu.Ft.)	2.6	2.6	2.2	2.2	2.1	1.8	1.8	1.5	1.5
Freezer compartment (Cu.Ft.)	0.4	0.4	0.2	0.2	0.4	0.1	0.1	0.1	0.1
Net weight (lbs.)	55.1	61.7	48.5	59.5	52.9	44.1	50.7	39.7	48.5
12-24 Vdc (Standard)	•	•	•	•	•	•	•	•	•
115-230Vac 50/60Hz (Optional)	•	•	•	•	•	•	•	•	•
Consumption	40W	40W	40W	40W	40W	40W	40W	31W	31W
Dimensions (in.)									
H	25 8/16	25 8/16	21 15/16	21 12/16	25 8/16	21 15/16	21 15/16	21 15/16	21 15/16
W	21	21	20 3/16	20 3/16	21	17 7/16	17 7/16	17 7/16	17 7/16
D	18 2/16	18 2/16	21 4/16	21 4/16	18	20 9/16	20 9/16	15 3/16	15 3/16





SPECIAL INSTALLATION

NEW THE RANGE
IS WIDENING

WHEN A NORMAL SOLUTION
WOULD NOT FIT...



Drawer color of your choice

D20A and D30A are available with a stainless steel door or with a white or black finish.

Thanks to commercial agreements, the refrigerator door color can be customized with any chosen shade, allowing the product to blend seamlessly into the surrounding decor.



Sport Grey version

Color available for both D20A HP and D30A HP

4 sided low height
fitting flange
included



Tailor made for mobile cooling



Low noise and vibrations

Remotable Cooling Unit

UP TO 4.9 ft.

More volume inside the fridge
and more installation options.

For further information, see at page 6

COMPACT DRAWER

REFRIGERATORS AND FREEZERS

Electronic LED thermostat

°F 50 14



Very low noise and high energy savings



NIGHT
MODE



FREEZER
MODE

Available
models

Total
volume

	Cu. Ft.	
D30AX HP	1.1	
D30A HP	1.1	
D20AX HP	0.7	
D20A HP	0.7	
C47	1.7	
C25LP	0.9	

OPTIONAL



Flush flange Surface flange

The position of the door (flush or external) is achieved by simply moving the special single fitting flange.

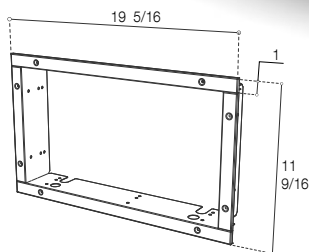

D30AX HP **R600a**
NextGen
compressor

D30A HP **R600a**
NextGen
compressor



H max
6 1/8 in.

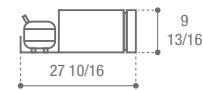
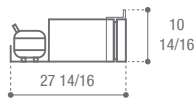

D20AX HP **R600a**
NextGen
compressor

D20A HP **R600a**
NextGen
compressor



H max
6 1/8 in.

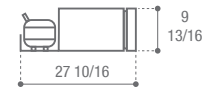
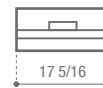
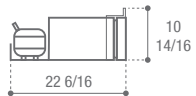

	D30AX HP	D30A HP	D20AX HP	D20A HP
Total volume (Cu.Ft.)	1.1	1.1	0.7	0.7
Net weight (lbs.)	37.5	30.8	33.1	26.5
Power supply (Vdc)	12/24	12/24	12/24	12/24
Consumption (Wh/24h)	241	241	150	150

Optional



Power
Supply

D30AX HP 115-230Vac
D30A HP 50/60Hz
D20AX HP 24Vdc/300W
D20A HP



C47 | R600a
compressor

Internal Cooling Unit

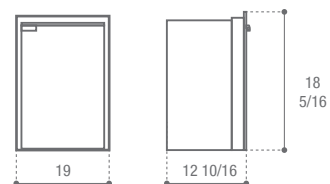
C25LP | R600a
compressor

External Cooling Unit

	C47	C25LP
Total volume (Cu.Ft.)	1.7	0.9
Net weight (lbs.)	41.9	26.5
Power supply (Vdc)	12/24	12/24
Consumption	285 Wh/24h	Nominal consumption 34W

Optional

Power
SupplyD30AX HP
D30A HP
D20AX HP
D20A HP115-230Vac
50/60Hz
24Vdc/300W



FRESH



FROZEN

FRIDGE + FREEZER



TOP LOADING



IDEAL TO RUN
FROM SOLAR POWER 24/7

3+ DAYS

RUNS FOR 3 OR MORE DAYS
ON A 100 A/H LEISURE BATTERY



FREEZER MODE
User-selectable freezer mode



NIGHT MODE
Lowest noise level and reduced
consumption during night time



EASY FIX
Hidden fixing points



RE-SEAL
Removable seal

OPTIONAL



**Dual electronic
control**

12-24Vdc
115-230Vac
50/60Hz



**External
drain**

Condensate conveyor
outside the vehicle.

**Removable
Cooling Unit**

UP TO 4.9 ft.

More volume inside the fridge and more installation
options.

OPTIONAL
TL43A

STANDARD
TL40, TL37

TOP LOADING REFRIGERATORS AND FREEZERS



Smart storage system

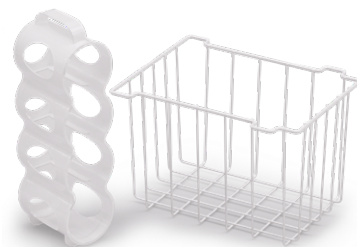

Available models	Total volume
	Cu. Ft.
TL43A	1.4
TL40L	1.4
TL37L	1.3
TL37BT	1.2
TL35	1.2
TL20A	0.7

TL43A



TL35



TL20A

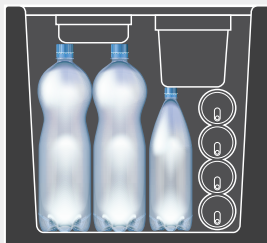

H max H max
10 7/16 in. 7 7/8 in.

Two removable food containers, and a useful container for storing cans.

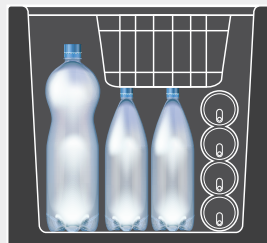

H max
7 7/8 in.

Removable wire basket and a useful container for storing cans.

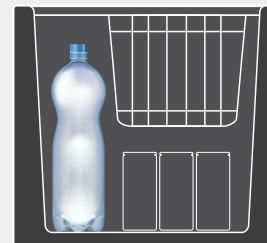

H max
6 11/16 in.

Removable wire basket.

TL43A | R600a
compressor

°F 50 14

NEW



T CLASS

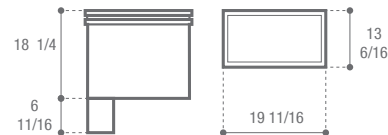

ST CLASS

Internal temperature
at 77°F ambient
temperature

39.2 °F

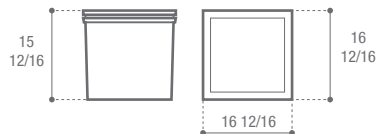
TL40L | R600a
compressor

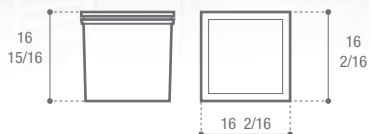
TL37L | R134a
compressor

TL37BT Available also as freezer version

TL35 | R600a
compressor

°F 50 / 33.8

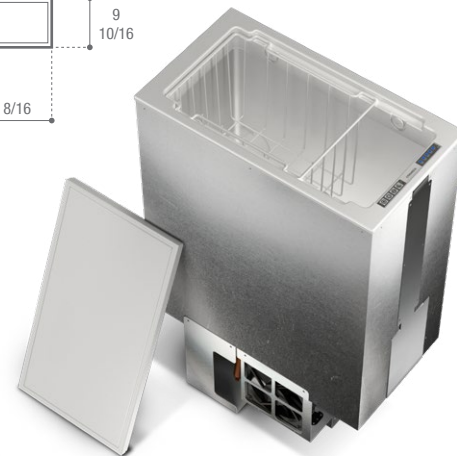
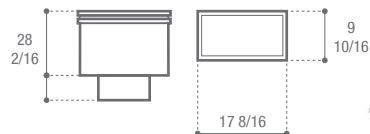
TL20A | R600a
compressor

NEW



(B) Black hinged door version

(A) Movable lid version

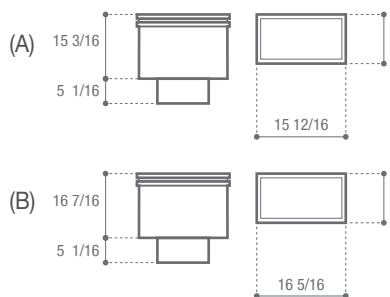

	TL43A	TL40L	TL37L	TL35	TL20A
Total volume (Cu.Ft.)	1.4	1.4	1.3	1.2	0.7
Net weight (lbs.)	27.6	22	33.1	33.1	22
Power supply (V)	12/24	12/24	12/24	12/24	12/24
Nominal Consumption (W)	45	31	31	28	28
Internal temperature (°F) at 77°F Ta	50/14	39.2	39.2	50/33.8	39.2
Power Pack (OPTIONAL) 115-230Vac 50/60Hz 24Vdc/300W	•	•	•	•	•

* 21.2 °F ** 10.4 °F *** -0.4°F

N Class: 60.8/89.6°F • ST Class: 60.8/100.4°F • T Class: 60.8/109.4°F

TECHNICAL DRAWINGS

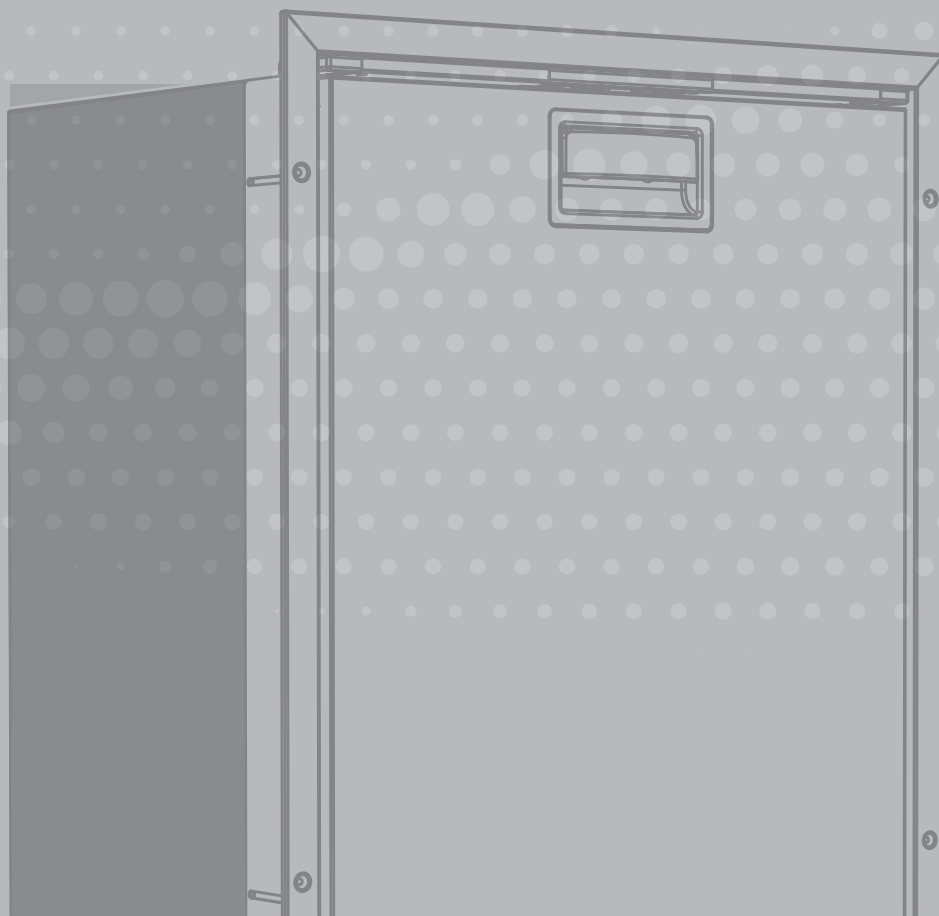

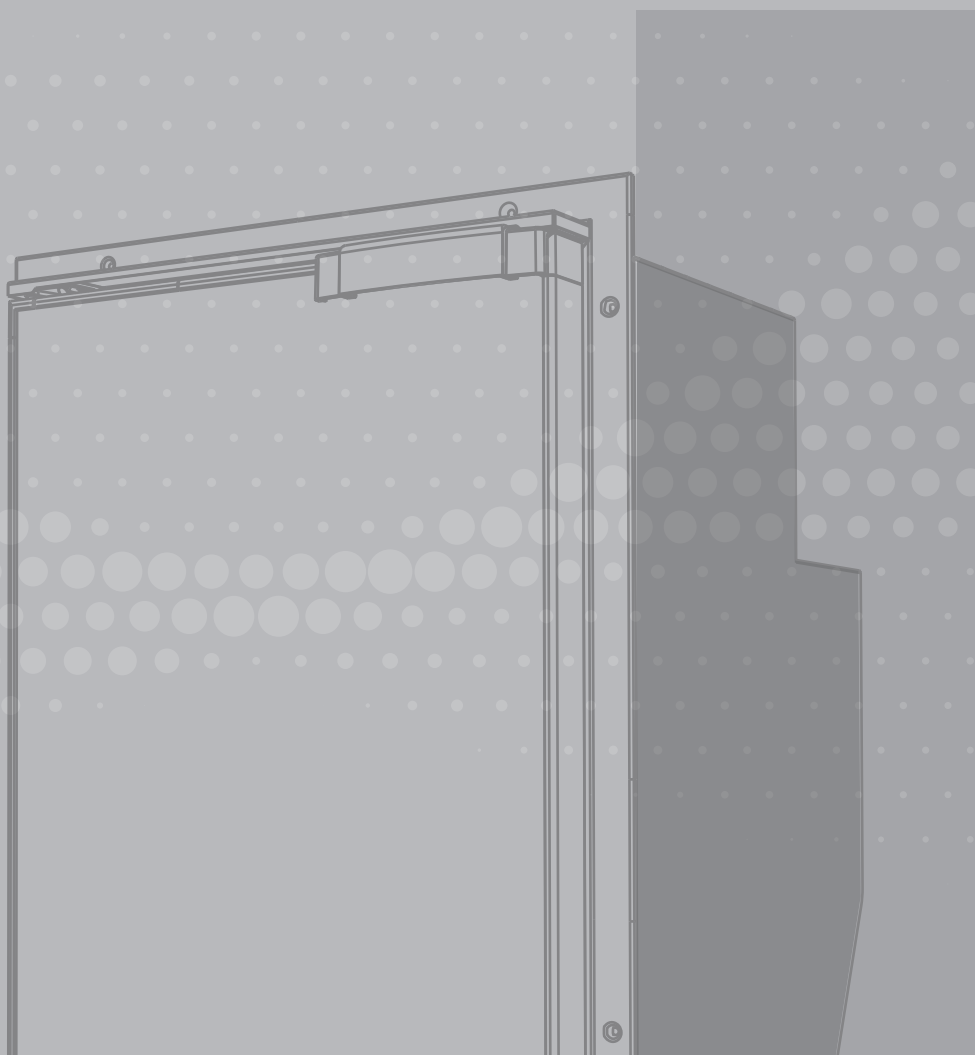

DP260iD CHR - DP260i CHR

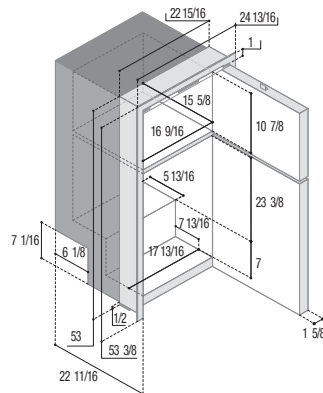

DP2600i

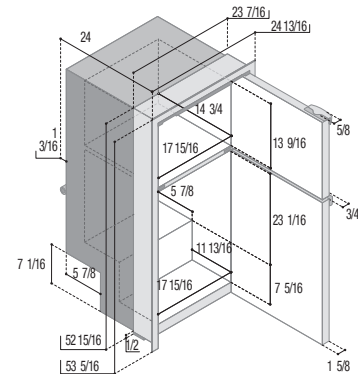

DP150iD CHR - DP150i CHR

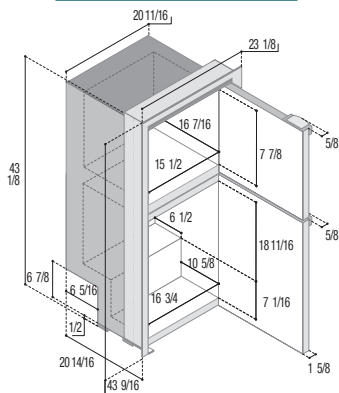

C130L CHR - C130LD CHR HP(*)



External Cooling Unit

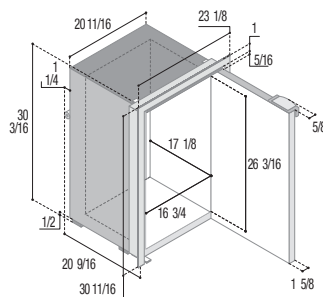

C115i CHR - C115iD CHR HP

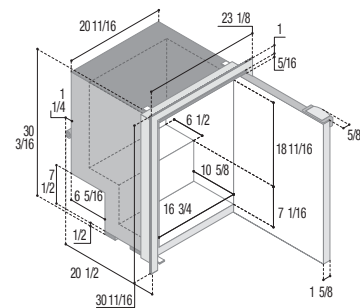

C95LD CHR HP



External Cooling Unit

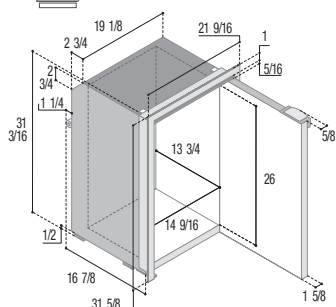

C90i CHR

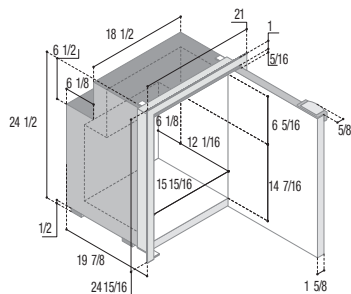

C90DWi CHR

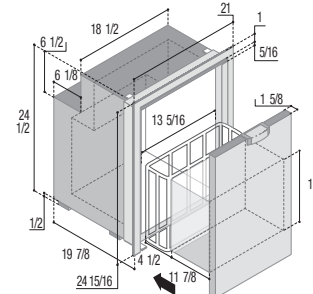

External Cooling Unit

CxxL CHR

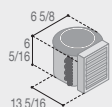

CxxLD CHR HP

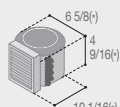

Flush flange | Surface flange

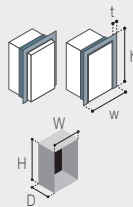

FLANGE

t:
w:

Mounting flange

h:

H:

W:

D:

FLANGE

Surface

Cut-out

	DP260iD CHR DP260i CHR		DP150iD CHR DP150i CHR		C130LD CHR HP C130L CHR		C115iD CHR HP C115i CHR		C95LD CHR HP C95L CHR		C90i CHR		C90DWi CHR	
	Flush	Surface	Flush	Surface	Flush	Surface	Flush	Surface	Flush	Surface	Flush	Surface	Flush	Surface
t:	1	1	1	1	1	1	1	1	1	1	1	1	1	1
w:	24 13/16	24 13/16	23 2/16	23 2/16	23 2/16	23 2/16	23 2/16	23 2/16	21 9/16	21 9/16	21	21	21	21
h:	53 6/16	53 6/16	43 10/16	43 10/16	30 11/16	30 11/16	30 11/16	30 11/16	31 10/16	31 10/16	24 15/16	24 15/16	24 15/16	24 15/16
H:	53 1/16	53 1/16	43 4/16	43 4/16	30 6/16	30 6/16	30 6/16	30 6/16	31 5/16	31 5/16	24 10/16	24 10/16	24 10/16	24 10/16
W:	23 1/16	23 1/16	21 5/16	21 5/16	21 5/16	21 5/16	21 5/16	21 5/16	19 13/16	19 13/16	19 3/16	19 3/16	19 3/16	19 3/16
D:	22 8/16	20 12/16	20 11/16	18 15/16	22 5/16	20 10/16	22 2/16	20 8/16	18 10/16	16 15/16	21 10/16	19 15/16	21 10/16	19 15/16

CHROMELOCK SERIES

C85iD CHR HP - C85i CHR

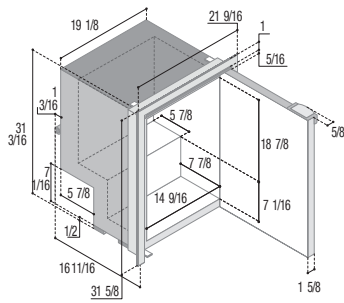

C75L CHR

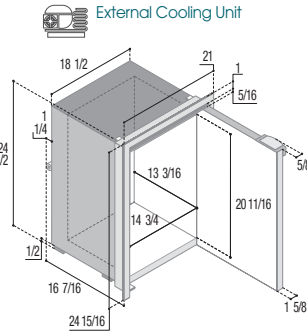

C75DWL CHR

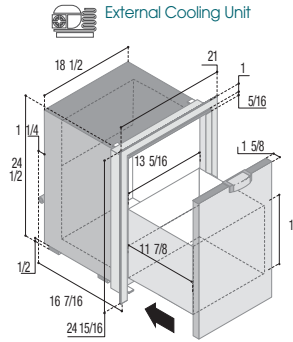

C62i CHR

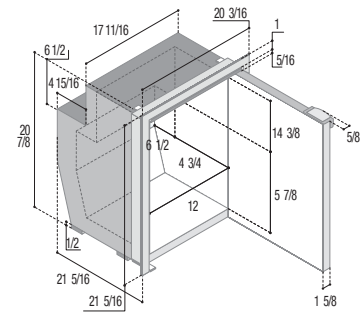

C62DWi CHR

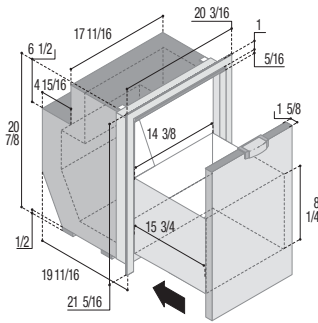

C60i CHR

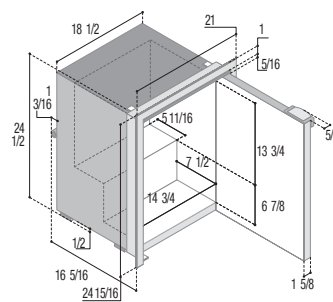

C51i CHR

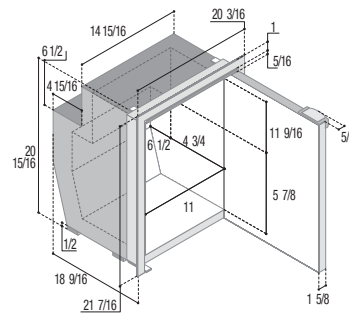

C51DWi CHR

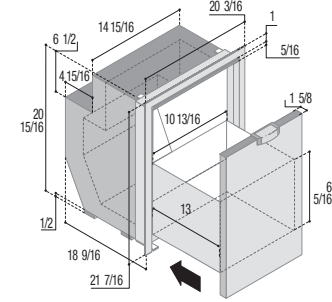

C50i CHR

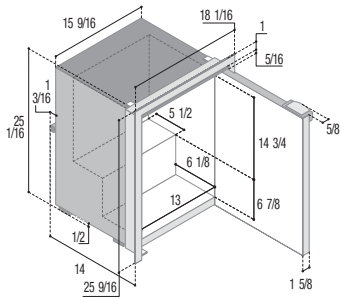

C42L CHR

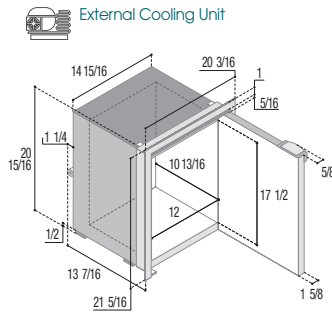

C42DWL CHR

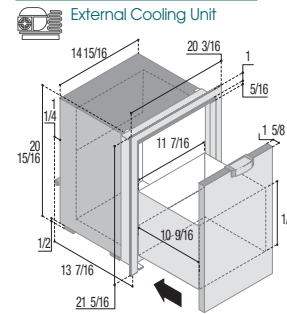

C39i CHR

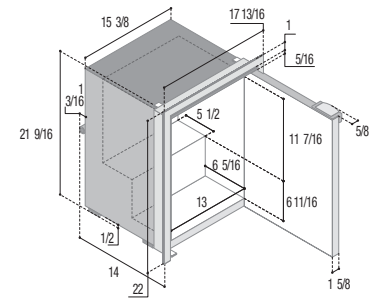

C85iD CHR HP C85i CHR		C75L CHR		C75DWL CHR		C62i CHR		C62DWi CHR		C60i CHR		C51i CHR		C51DWi CHR		C50i CHR		C42L CHR		C42DWL CHR		C39i CHR	
Flush	Surface	Flush	Surface	Flush	Surface	Flush	Surface	Flush	Surface	Flush	Surface	Flush	Surface	Flush	Surface	Flush	Surface	Flush	Surface	Flush	Surface	Flush	Surface
21 9/16	21 9/16	21	21	21	21	20 3/16	20 3/16	20 3/16	20 3/16	21	21	17 7/16	17 7/16	17 7/16	17 7/16	18 1/16	18 1/16	17 7/16	17 7/16	17 7/16	17 7/16	17 13/16	17 13/16
31 10/16	31 10/16	24 15/16	24 15/16	24 15/16	24 15/16	21 5/16	21 5/16	21 5/16	21 5/16	24 15/16	24 15/16	21 7/16	21 7/16	21 7/16	21 7/16	25 9/16	25 9/16	21 7/16	21 7/16	21 7/16	21 7/16	22	22
31 5/16	31 5/16	24 10/16	24 10/16	24 10/16	24 10/16	21 2/16	21 2/16	21 2/16	21 2/16	24 10/16	24 10/16	21 2/16	21 2/16	21 2/16	21 2/16	25 3/16	25 3/16	21 2/16	21 2/16	21 2/16	21 2/16	21 10/16	21 10/16
19 13/16	19 13/16	19 3/16	19 3/16	19 3/16	19 3/16	18 7/16	18 7/16	18 7/16	18 7/16	19 3/16	19 3/16	15 11/16	15 11/16	15 11/16	15 11/16	16 5/16	16 5/16	15 11/16	15 11/16	15 11/16	15 11/16	16 1/16	16 1/16
18 7/16	16 12/16	18 3/16	16 9/16	18 3/16	16 9/16	21 7/16	19 12/16	21 7/16	19 12/16	18 1/16	16 7/16	20 5/16	18 11/16	20 5/16	18 11/16	15 11/16	14 1/16	15 3/16	13 9/16	15 3/16	13 9/16	15 11/16	14 1/16

SLIM250 CHR HP

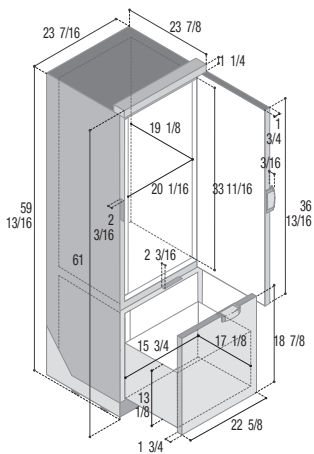

SLIM150 CHR

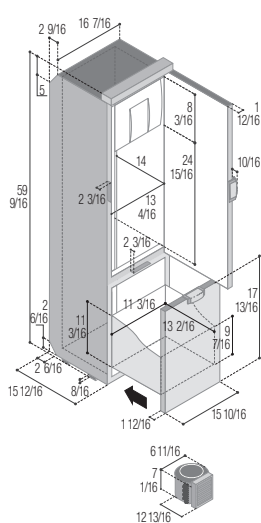

SLIM90M CHR

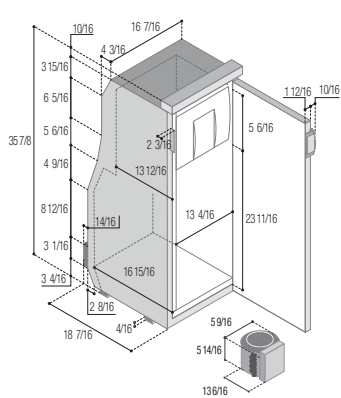

SLIM90 CHR HP

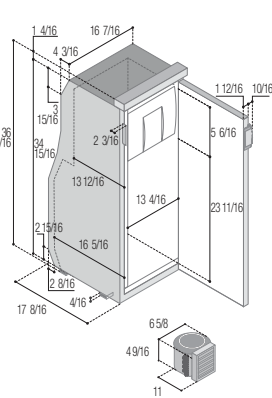

SLIM90i CHR HP

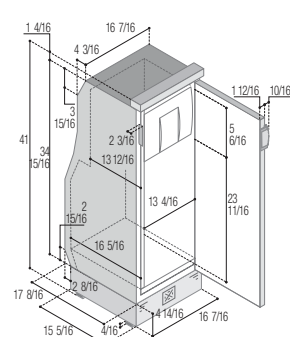
DRW OX2 SERIES
DW OX2 SERIES

DRW360A

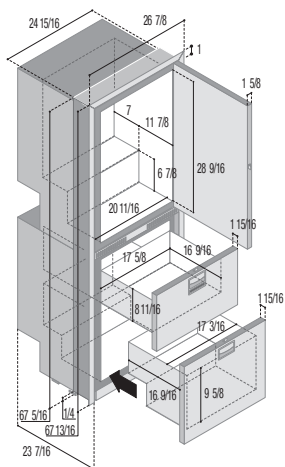

DRW180A

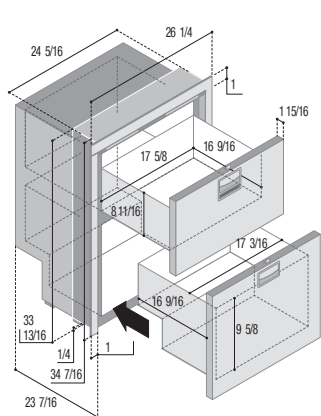

DRW70A

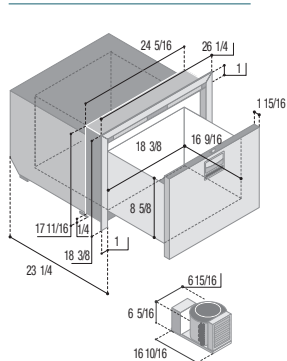

DRW360 OX2

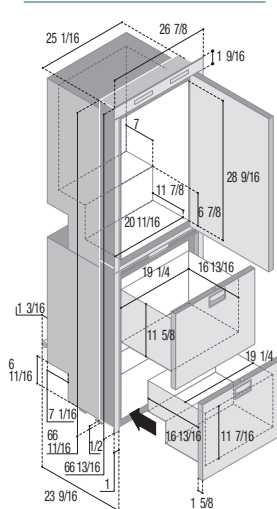

Flush Flange | Surface Flange

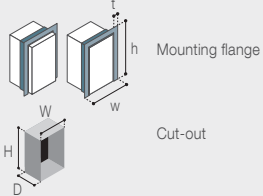

FLANGE	DRW360A		DRW180A		DRW70A		DW360 OX2		DW250 OX2		DW210 OX2	
	Flush	Surface	Flush	Surface	Flush	Surface	Flush	Surface	Flush	Surface	Flush	Surface
t	1	1	1	1	1	1	1 - 1 9/16	1 - 1 9/16	1 - 1 9/16	1 - 1 9/16	1 - 1 9/16	1 - 1 9/16
w	26 14/16	26 14/16	26 4/16	26 4/16	26 4/16	26 4/16	26 14/16	26 14/16	26 14/16	26 14/16	29 2/16	29 2/16
h	67 13/16	67 13/16	34 7/16	34 7/16	18 6/16	18 6/16	66 13/16	66 13/16	51 15/16	51 15/16	34 10/16	34 10/16
H	67 6/16	67 6/16	33 14/16	33 14/16	17 13/16	17 13/16	66 12/16	66 12/16	51 15/16	51 15/16	34 5/16	34 5/16
W	25 1/16	25 1/16	24 7/16	24 7/16	24 7/16	24 7/16	25 3/16	25 3/16	25 3/16	25 3/16	27 5/16	27 5/16
D	23 8/16	21 9/16	23 8/16	21 9/16	23 6/16	21 6/16	23 11/16	21 15/16	23 9/16	21 14/16	25 1/16	23 5/16

DW OCX2 SERIES
DW DRINKS OCX2 SERIES

DW250 OCX2

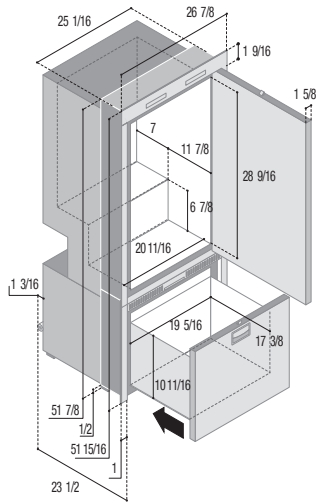

DW210 OCX2

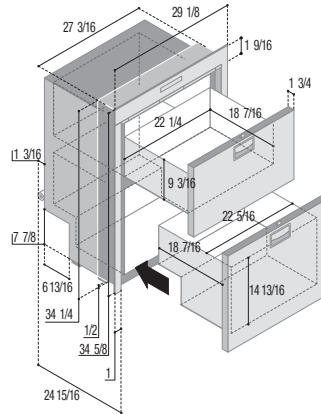

DW180 OCX2

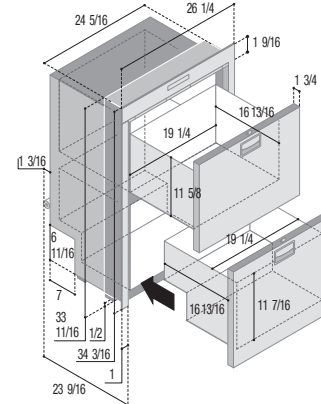

DW100 OCX2

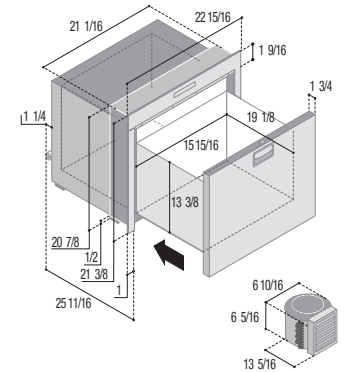

DW70 OCX2

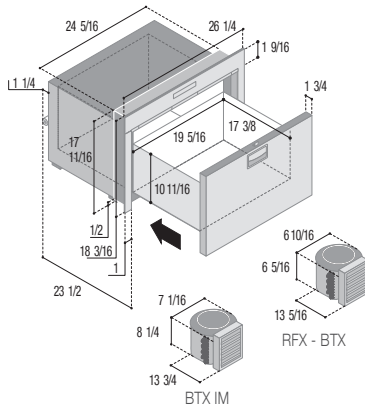

DW35 OCX2

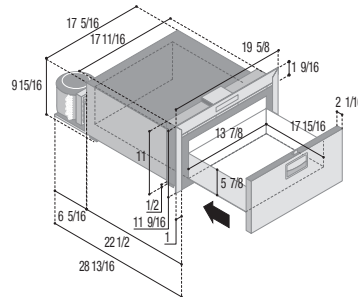

DW90i OCX2 DRINKS

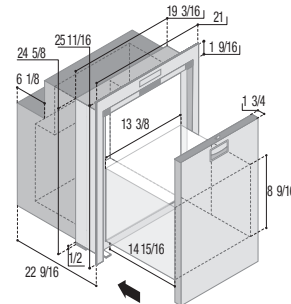

DW62i OCX2 DRINKS

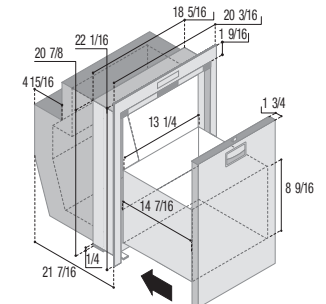

DW70 OCX2 BTX IM

Total depth: 23 2/16 in. (Surface flange)
24 10/16 in. (Flush flange)

DW51i OCX2 DRINKS

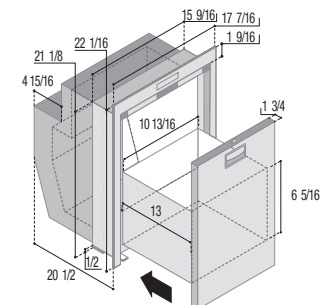

FLANGE	DW180 OCX2		DW100 OCX2		DW70 OCX2		DW35 OCX2		DW90i OCX2 DRINKS		DW62i OCX2 DRINKS		DW51i OCX2 DRINKS	
	Flush	Surface	Flush	Surface	Flush	Surface	Flush	Surface	Flush	Surface	Flush	Surface	Flush	Surface
t	1 - 1 9/16	1 - 1 9/16	1 - 1 9/16	1 - 1 9/16	1 - 1 9/16	1 - 1 9/16	1 - 1 9/16	1 - 1 9/16	1	1	1	1	1	1
w	26 4/16	26 4/16	22 15/16	22 15/16	26 4/16	26 4/16	19 10/16	19 10/16	21	21	20 3/16	20 3/16	17 7/16	17 7/16
h	34 3/16	34 3/16	21 6/16	21 6/16	18 3/16	18 3/16	11 9/16	11 9/16	25 11/16	25 11/16	22 1/16	22 1/16	22 1/16	22 1/16
H	33 12/16	33 12/16	20 15/16	20 15/16	17 13/16	17 13/16	11 2/16	11 2/16	24 12/16	24 12/16	20 15/16	20 15/16	21 4/16	21 4/16
W	24 7/16	24 7/16	21 3/16	21 3/16	24 7/16	24 7/16	17 13/16	17 13/16	19 5/16	19 5/16	18 7/16	18 7/16	15 11/16	15 11/16
D	23 11/16	21 15/16	25 12/16	24	23 9/16	21 14/16	28 14/16	26 15/16	22 10/16	20 14/16	21 9/16	19 13/16	20 9/16	18 12/16

STAINLESS STEEL OCX2 SERIES

DP260iXD OCX2 - DP260iX OCX2

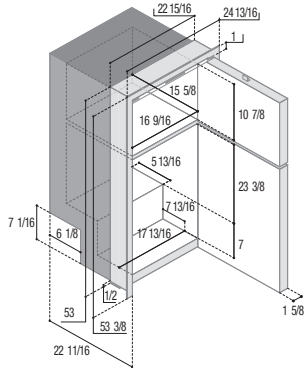

DP2600iX OCX2

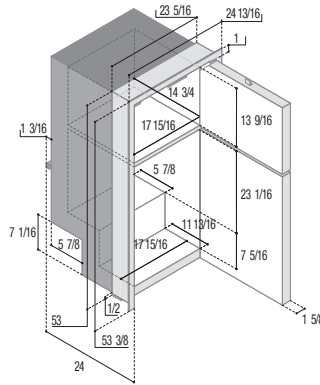

C180iX OCX2

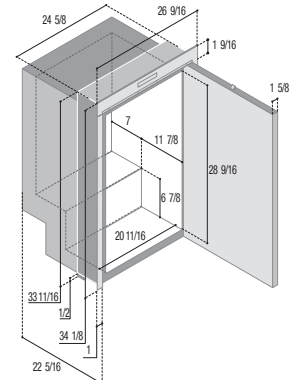

C130LXD OCX2 HP(*) - C130LX OCX2



External Cooling Unit

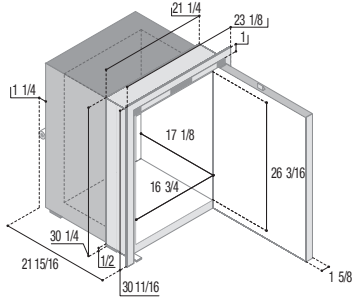

C115iXD OCX2 HP - C115iX OCX2

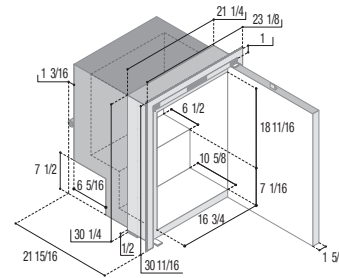

C90iX OCX2

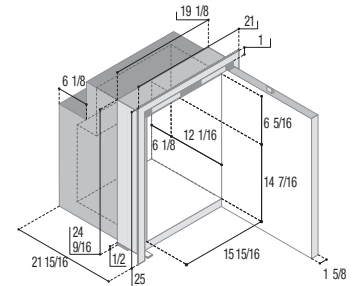

DW90i OCX2

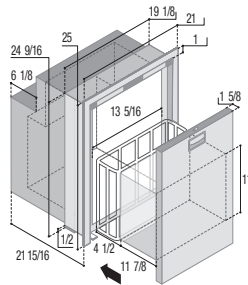

C85iXD OCX2 HP - C85iX OCX2

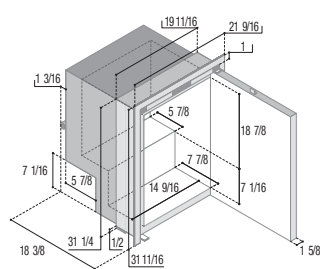

C75LX OCX2



External Cooling Unit

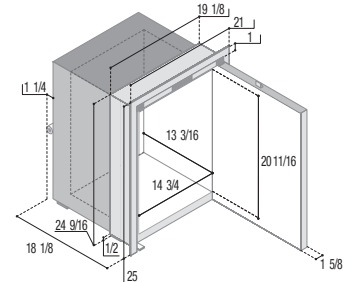

External Cooling Unit

CxxL CHR

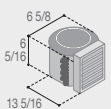

CxxLD CHR HP

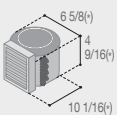

Flush flange | Surface flange

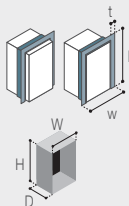

FLANGE

t

Mounting flange

h:

H

W

D

Flush

Surface

Flush

Surface

Flush

Surface

Flush

Surface

	DP260iXD OCX2 DP260iX OCX2		DP2600iX OCX2		C180iX OCX2		C130LXD OCX2 HP(*) C130LX OCX2		C115iXD OCX2 HP C115iX OCX2		C90iX OCX2	
	Flush	Surface	Flush	Surface	Flush	Surface	Flush	Surface	Flush	Surface	Flush	Surface
Mounting flange	1	1	1	1	1	1	1	1	1	1	1	1
h:	24 13/16	24 13/16	24 13/16	24 13/16	26 9/16	26 9/16	23 2/16	23 2/16	23 2/16	23 2/16	21	21
H	53 6/16	53 6/16	53 6/16	53 6/16	34 2/16	34 2/16	30 11/16	30 11/16	30 11/16	30 11/16	25	25
W	53 1/16	53 1/16	53 1/16	53 1/16	33 12/16	33 12/16	30 6/16	30 6/16	30 6/16	30 6/16	24 10/16	24 10/16
D	23 7/16	23 7/16	23 7/16	23 7/16	24 12/16	24 12/16	21 5/16	21 5/16	21 6/16	21 6/16	19 3/16	19 3/16
	22 13/16	21 2/16	24 2/16	22 7/16	22 6/16	20 11/16	22 1/16	20 6/16	22	20 4/16	22 1/16	20 4/16

STAINLESS STEEL OCX2 SERIES

DW75L OCX2

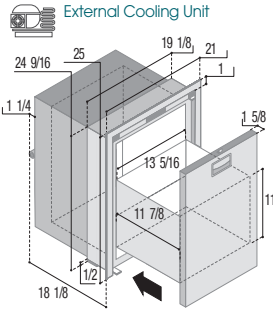

C62IX OCX2

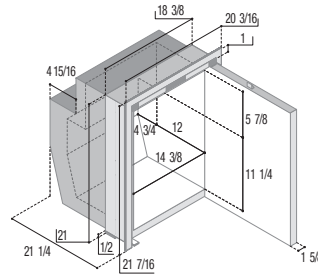

DW62i OCX2

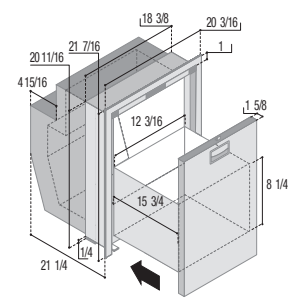

C60IX OCX2

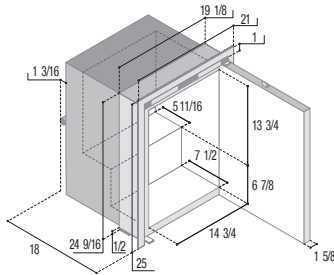

C51IX OCX2

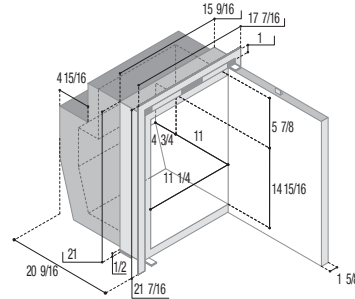

DW51i OCX2

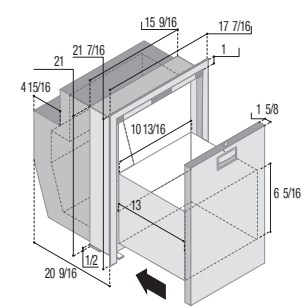

C42LX OCX2

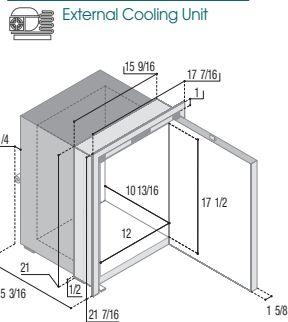

DW42L OCX2

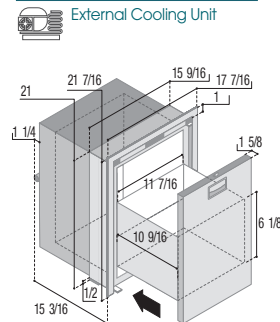

FLANGE	DW90i OCX2		C85XD OCX2 HP C85IX OCX2		C75LX OCX2		DW75L OCX2		C62IX OCX2		DW62i OCX2		C60IX OCX2		C51IX OCX2		DW51i OCX2		C42LX OCX2		DW42L OCX2	
	Flush	Surface	Flush	Surface	Flush	Surface	Flush	Surface	Flush	Surface	Flush	Surface	Flush	Surface	Flush	Surface	Flush	Surface	Flush	Surface	Flush	Surface
t:	1	1	1	1	1	1	1	1	1	1	1	1	1	1	1	1	1	1	1	1	1	1
w	21	21	21 9/16	21 9/16	21	21	21	21	20 3/16	20 3/16	20 3/16	20 3/16	21	21	17 7/16	17 7/16	17 7/16	17 7/16	17 7/16	17 7/16	17 7/16	17 7/16
h	25	25	31 11/16	31 11/16	25	25	25	25	21 7/16	21 7/16	21 12/16	21 12/16	25	25	21 7/16	21 7/16	21 7/16	21 7/16	21 7/16	21 7/16	21 7/16	21 7/16
H	24 10/16	24 10/16	31 5/16	31 5/16	24 10/16	24 10/16	24 10/16	24 10/16	21 2/16	21 2/16	20 13/16	20 13/16	24 10/16	24 10/16	21 2/16	21 2/16	21 2/16	21 2/16	21 2/16	21 2/16	21 2/16	21 2/16
W	19 3/16	19 3/16	19 13/16	19 13/16	19 3/16	19 3/16	19 3/16	19 3/16	18 8/16	18 8/16	18 8/16	18 8/16	19 3/16	19 3/16	15 11/16	15 11/16	15 11/16	15 11/16	15 11/16	15 11/16	15 11/16	15 11/16
D	22 1/16	20 4/16	18 7/16	16 10/16	18 3/16	16 4/16	18 3/16	16 7/16	21 5/16	19 9/16	21 5/16	19 9/16	18 1/16	16 5/16	20 11/16	18 14/16	20 11/16	18 14/16	15 4/16	13 7/16	15 4/16	13 7/16

SPECIAL INSTALLATIONS SERIES
TOP LOADING SERIES

D30AX HP

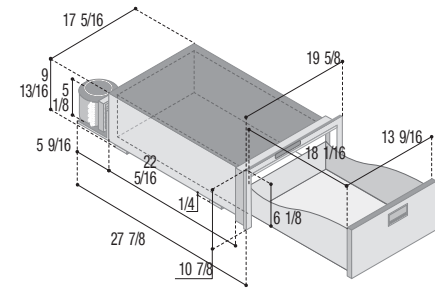

D30A HP

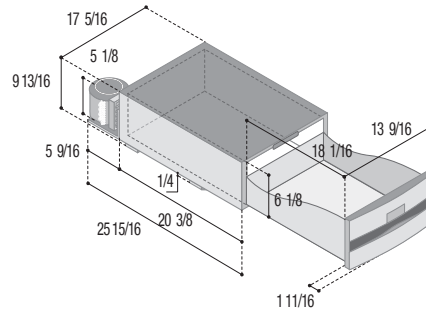

D20AX HP

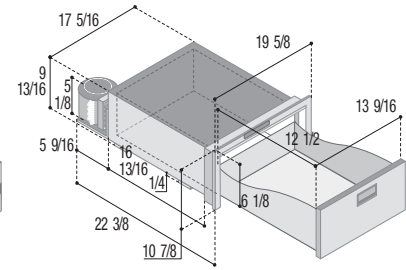

D20A HP

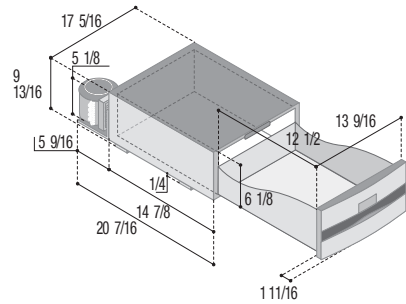

C47

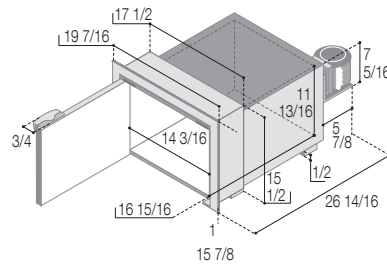

C25LP

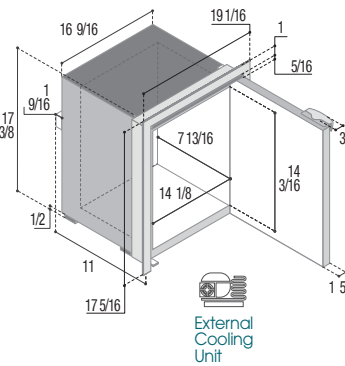

TL43

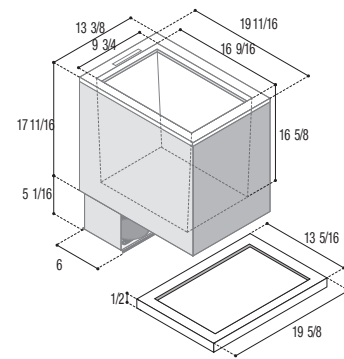

External Cooling Unit

TL40L

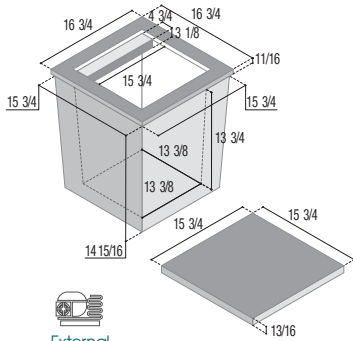

External Cooling Unit

TL37L

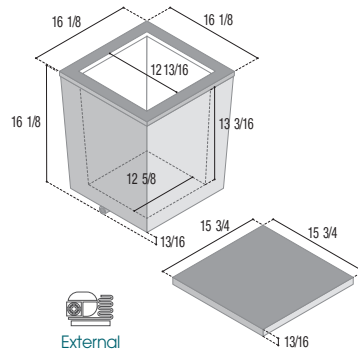

External Cooling Unit

TL35RF

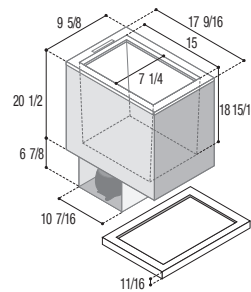

TL20RF

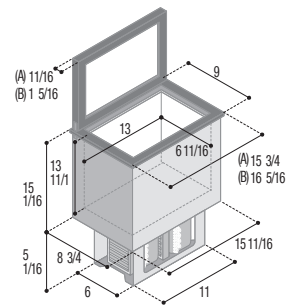

- (A) Movable lid version
- (B) Black hinged door version



External Cooling Unit

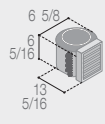

Flush flange | Surface flange

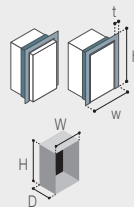

FLANGE

t
h
w
Mounting flange

W
H
D
Cut-out

C47

	Inside	Outside
t	1	1
h	19 7/16	19 7/16
w	15 14/16	15 14/16
W	15 9/16	15 9/16
H	17 10/16	17 10/16
D	26 14/16	25 3/16

C25LP

	Inside	Outside
t	1	1
h	19 1/16	19 1/16
w	17 14/16	17 14/16
W	17 1/16	17 1/16
H	17 5/16	17 5/16
D	12 11/16	11



VITRIFRIGO
COOL AND BEYOND



STAY TUNED



Vitrifrigo America LLC

**2200 N.W. 32 St. , Suite 1200
Pompano Beach, FL 33069**

Sales office
3535 Gravel Springs Rd Ext, Buford, GA 30519

Phone: 954.979.7737
Fax: 954.979.7740

**www.vitrifrigo.com
marketing@vfamerica.com**